

POWER FEED[®] 25M

For use with machine code numbers 11313

Safety Depends on You

Lincoln arc welding and cutting equipment is designed and built with safety in mind. However, your overall safety can be increased by proper installation . . . and thoughtful operation on your part. **DO NOT INSTALL, OPERATE OR REPAIR THIS EQUIPMENT WITHOUT READING THIS MANUAL AND THE SAFETY PRECAUTIONS CONTAINED THROUGHOUT.** And, most importantly, think before you act and be careful.

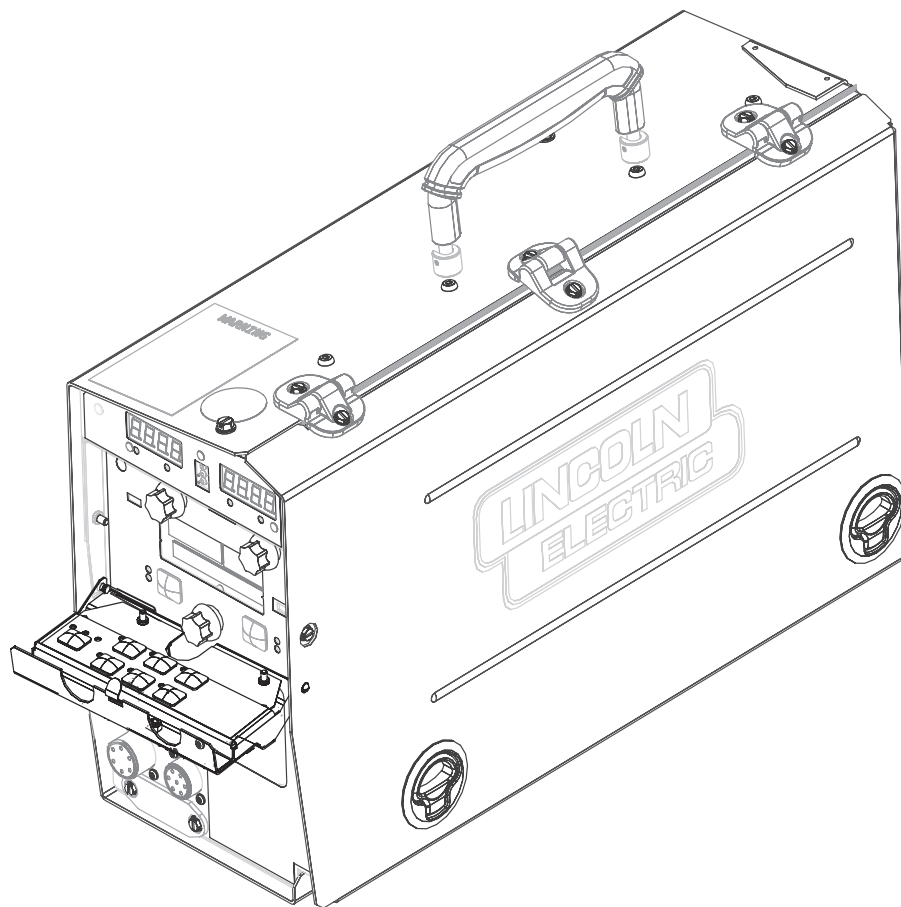

SERVICE MANUAL



Copyright © Lincoln Global Inc.

• World's Leader in Welding and Cutting Products •

• Sales and Service through Subsidiaries and Distributors Worldwide •

Cleveland, Ohio 44117-1199 U.S.A. TEL: 888.935.3877 FAX: 216.486.1751 WEB SITE: www.lincolnelectric.com

⚠ WARNING

⚠ CALIFORNIA PROPOSITION 65 WARNINGS ⚠

Diesel engine exhaust and some of its constituents are known to the State of California to cause cancer, birth defects, and other reproductive harm.

The Above For Diesel Engines

The engine exhaust from this product contains chemicals known to the State of California to cause cancer, birth defects, or other reproductive harm.

The Above For Gasoline Engines

ARC WELDING can be hazardous. PROTECT YOURSELF AND OTHERS FROM POSSIBLE SERIOUS INJURY OR DEATH. KEEP CHILDREN AWAY. PACEMAKER WEARERS SHOULD CONSULT WITH THEIR DOCTOR BEFORE OPERATING.

Read and understand the following safety highlights. For additional safety information, it is strongly recommended that you purchase a copy of "Safety in Welding & Cutting - ANSI Standard Z49.1" from the American Welding Society, P.O. Box 351040, Miami, Florida 33135 or CSA Standard W117.2-1974. A Free copy of "Arc Welding Safety" booklet E205 is available from the Lincoln Electric Company, 22801 St. Clair Avenue, Cleveland, Ohio 44117-1199.

BE SURE THAT ALL INSTALLATION, OPERATION, MAINTENANCE AND REPAIR PROCEDURES ARE PERFORMED ONLY BY QUALIFIED INDIVIDUALS.



FOR ENGINE powered equipment.

1.a. Turn the engine off before troubleshooting and maintenance work unless the maintenance work requires it to be running.



1.b. Operate engines in open, well-ventilated areas or vent the engine exhaust fumes outdoors.



1.c. Do not add the fuel near an open flame welding arc or when the engine is running. Stop the engine and allow it to cool before refueling to prevent spilled fuel from vaporizing on contact with hot engine parts and igniting. Do not spill fuel when filling tank. If fuel is spilled, wipe it up and do not start engine until fumes have been eliminated.

1.d. Keep all equipment safety guards, covers and devices in position and in good repair. Keep hands, hair, clothing and tools away from V-belts, gears, fans and all other moving parts when starting, operating or repairing equipment.

1.e. In some cases it may be necessary to remove safety guards to perform required maintenance. Remove guards only when necessary and replace them when the maintenance requiring their removal is complete. Always use the greatest care when working near moving parts.



1.f. Do not put your hands near the engine fan. Do not attempt to override the governor or idler by pushing on the throttle control rods while the engine is running.

1.g. To prevent accidentally starting gasoline engines while turning the engine or welding generator during maintenance work, disconnect the spark plug wires, distributor cap or magneto wire as appropriate.



1.h. To avoid scalding, do not remove the radiator pressure cap when the engine is hot.

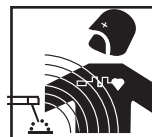

ELECTRIC AND MAGNETIC FIELDS may be dangerous

2.a. Electric current flowing through any conductor causes localized Electric and Magnetic Fields (EMF). Welding current creates EMF fields around welding cables and welding machines

2.b. EMF fields may interfere with some pacemakers, and welders having a pacemaker should consult their physician before welding.

2.c. Exposure to EMF fields in welding may have other health effects which are now not known.

2.d. All welders should use the following procedures in order to minimize exposure to EMF fields from the welding circuit:

2.d.1. Route the electrode and work cables together - Secure them with tape when possible.

2.d.2. Never coil the electrode lead around your body.

2.d.3. Do not place your body between the electrode and work cables. If the electrode cable is on your right side, the work cable should also be on your right side.

2.d.4. Connect the work cable to the workpiece as close as possible to the area being welded.

2.d.5. Do not work next to welding power source.

Mar '95

POWER FEED® 25M

LINCOLN
ELECTRIC



ELECTRIC SHOCK can kill.

3.a. The electrode and work (or ground) circuits are electrically "hot" when the welder is on. Do not touch these "hot" parts with your bare skin or wet clothing. Wear dry, hole-free gloves to insulate hands.

3.b. Insulate yourself from work and ground using dry insulation. Make certain the insulation is large enough to cover your full area of physical contact with work and ground.

In addition to the normal safety precautions, if welding must be performed under electrically hazardous conditions (in damp locations or while wearing wet clothing; on metal structures such as floors, gratings or scaffolds; when in cramped positions such as sitting, kneeling or lying, if there is a high risk of unavoidable or accidental contact with the workpiece or ground) use the following equipment:

- Semiautomatic DC Constant Voltage (Wire) Welder.
- DC Manual (Stick) Welder.
- AC Welder with Reduced Voltage Control.

3.c. In semiautomatic or automatic wire welding, the electrode, electrode reel, welding head, nozzle or semiautomatic welding gun are also electrically "hot".

3.d. Always be sure the work cable makes a good electrical connection with the metal being welded. The connection should be as close as possible to the area being welded.

3.e. Ground the work or metal to be welded to a good electrical (earth) ground.

3.f. Maintain the electrode holder, work clamp, welding cable and welding machine in good, safe operating condition. Replace damaged insulation.

3.g. Never dip the electrode in water for cooling.

3.h. Never simultaneously touch electrically "hot" parts of electrode holders connected to two welders because voltage between the two can be the total of the open circuit voltage of both welders.

3.i. When working above floor level, use a safety belt to protect yourself from a fall should you get a shock.

3.j. Also see Items 6.c. and 8.



ARC RAYS can burn.

4.a. Use a shield with the proper filter and cover plates to protect your eyes from sparks and the rays of the arc when welding or observing open arc welding. Headshield and filter lens should conform to ANSI Z87.1 standards.

4.b. Use suitable clothing made from durable flame-resistant material to protect your skin and that of your helpers from the arc rays.

4.c. Protect other nearby personnel with suitable, non-flammable screening and/or warn them not to watch the arc nor expose themselves to the arc rays or to hot spatter or metal.



FUMES AND GASES can be dangerous.

5.a. Welding may produce fumes and gases hazardous to health. Avoid breathing these fumes and gases. When welding, keep your head out of the fume. Use enough ventilation and/or exhaust at the arc to keep

fumes and gases away from the breathing zone. **When welding with electrodes which require special ventilation such as stainless or hard facing (see instructions on container or MSDS) or on lead or cadmium plated steel and other metals or coatings which produce highly toxic fumes, keep exposure as low as possible and below Threshold Limit Values (TLV) using local exhaust or mechanical ventilation. In confined spaces or in some circumstances, outdoors, a respirator may be required. Additional precautions are also required when welding on galvanized steel.**

5. b. The operation of welding fume control equipment is affected by various factors including proper use and positioning of the equipment, maintenance of the equipment and the specific welding procedure and application involved. Worker exposure level should be checked upon installation and periodically thereafter to be certain it is within applicable OSHA PEL and ACGIH TLV limits.

5.c. Do not weld in locations near chlorinated hydrocarbon vapors coming from degreasing, cleaning or spraying operations. The heat and rays of the arc can react with solvent vapors to form phosgene, a highly toxic gas, and other irritating products.

5.d. Shielding gases used for arc welding can displace air and cause injury or death. Always use enough ventilation, especially in confined areas, to insure breathing air is safe.

5.e. Read and understand the manufacturer's instructions for this equipment and the consumables to be used, including the material safety data sheet (MSDS) and follow your employer's safety practices. MSDS forms are available from your welding distributor or from the manufacturer.

5.f. Also see item 1.b.

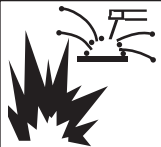

WELDING and CUTTING SPARKS can cause fire or explosion.

6.a. Remove fire hazards from the welding area. If this is not possible, cover them to prevent the welding sparks from starting a fire.

Remember that welding sparks and hot materials from welding can easily go through small cracks and openings to adjacent areas. Avoid welding near hydraulic lines. Have a fire extinguisher readily available.

6.b. Where compressed gases are to be used at the job site, special precautions should be used to prevent hazardous situations. Refer to "Safety in Welding and Cutting" (ANSI Standard Z49.1) and the operating information for the equipment being used.

6.c. When not welding, make certain no part of the electrode circuit is touching the work or ground. Accidental contact can cause overheating and create a fire hazard.

6.d. Do not heat, cut or weld tanks, drums or containers until the proper steps have been taken to insure that such procedures will not cause flammable or toxic vapors from substances inside. They can cause an explosion even though they have been "cleaned". For information, purchase "Recommended Safe Practices for the Preparation for Welding and Cutting of Containers and Piping That Have Held Hazardous Substances", AWS F4.1 from the American Welding Society (see address above).

6.e. Vent hollow castings or containers before heating, cutting or welding. They may explode.

6.f. Sparks and spatter are thrown from the welding arc. Wear oil free protective garments such as leather gloves, heavy shirt, cuffless trousers, high shoes and a cap over your hair. Wear ear plugs when welding out of position or in confined places. Always wear safety glasses with side shields when in a welding area.

6.g. Connect the work cable to the work as close to the welding area as practical. Work cables connected to the building framework or other locations away from the welding area increase the possibility of the welding current passing through lifting chains, crane cables or other alternate circuits. This can create fire hazards or overheat lifting chains or cables until they fail.

6.h. Also see item 1.c.

6.i. Read and follow NFPA 51B "Standard for Fire Prevention During Welding, Cutting and Other Hot Work", available from NFPA, 1 Batterymarch Park, PO box 9101, Quincy, Ma 022690-9101.

6.j. Do not use a welding power source for pipe thawing.



CYLINDER may explode if damaged.

7.a. Use only compressed gas cylinders containing the correct shielding gas for the process used and properly operating regulators designed for the gas and pressure used. All hoses, fittings, etc. should be suitable for the application and maintained in good condition.

7.b. Always keep cylinders in an upright position securely chained to an undercarriage or fixed support.

7.c. Cylinders should be located:

- Away from areas where they may be struck or subjected to physical damage.

- A safe distance from arc welding or cutting operations and any other source of heat, sparks, or flame.

7.d. Never allow the electrode, electrode holder or any other electrically "hot" parts to touch a cylinder.

7.e. Keep your head and face away from the cylinder valve outlet when opening the cylinder valve.

7.f. Valve protection caps should always be in place and hand tight except when the cylinder is in use or connected for use.

7.g. Read and follow the instructions on compressed gas cylinders, associated equipment, and CGA publication P-1, "Precautions for Safe Handling of Compressed Gases in Cylinders," available from the Compressed Gas Association 1235 Jefferson Davis Highway, Arlington, VA 22202.



FOR ELECTRICALLY powered equipment.

8.a. Turn off input power using the disconnect switch at the fuse box before working on the equipment.

8.b. Install equipment in accordance with the U.S. National Electrical Code, all local codes and the manufacturer's recommendations.

8.c. Ground the equipment in accordance with the U.S. National Electrical Code and the manufacturer's recommendations.

PRÉCAUTIONS DE SÛRETÉ

Pour votre propre protection lire et observer toutes les instructions et les précautions de sûreté spécifiques qui paraissent dans ce manuel aussi bien que les précautions de sûreté générales suivantes:

Sûreté Pour Soudage A L'Arc

1. Protégez-vous contre la secousse électrique:
 - a. Les circuits à l'électrode et à la pièce sont sous tension quand la machine à souder est en marche. Eviter toujours tout contact entre les parties sous tension et la peau nue ou les vêtements mouillés. Porter des gants secs et sans trous pour isoler les mains.
 - b. Faire très attention de bien s'isoler de la masse quand on soude dans des endroits humides, ou sur un plancher métallique ou des grilles métalliques, principalement dans les positions assis ou couché pour lesquelles une grande partie du corps peut être en contact avec la masse.
 - c. Maintenir le porte-électrode, la pince de masse, le câble de soudage et la machine à souder en bon et sûr état de fonctionnement.
 - d. Ne jamais plonger le porte-électrode dans l'eau pour le refroidir.
 - e. Ne jamais toucher simultanément les parties sous tension des porte-électrodes connectés à deux machines à souder parce que la tension entre les deux pinces peut être le total de la tension à vide des deux machines.
 - f. Si on utilise la machine à souder comme une source de courant pour soudage semi-automatique, ces précautions pour le porte-électrode s'appliquent aussi au pistolet de soudage.
2. Dans le cas de travail au dessus du niveau du sol, se protéger contre les chutes dans le cas où on reçoit un choc. Ne jamais enrouler le câble-électrode autour de n'importe quelle partie du corps.
3. Un coup d'arc peut être plus sévère qu'un coup de soliel, donc:
 - a. Utiliser un bon masque avec un verre filtrant approprié ainsi qu'un verre blanc afin de se protéger les yeux du rayonnement de l'arc et des projections quand on soude ou quand on regarde l'arc.
 - b. Porter des vêtements convenables afin de protéger la peau de soudeur et des aides contre le rayonnement de l'arc.
 - c. Protéger l'autre personnel travaillant à proximité au soudage à l'aide d'écrans appropriés et non-inflammables.
4. Des gouttes de laitier en fusion sont émises de l'arc de soudage. Se protéger avec des vêtements de protection libres de l'huile, tels que les gants en cuir, chemise épaisse, pantalons sans revers, et chaussures montantes.
5. Toujours porter des lunettes de sécurité dans la zone de soudage. Utiliser des lunettes avec écrans latéraux dans les zones où l'on pique le laitier.

6. Eloigner les matériaux inflammables ou les recouvrir afin de prévenir tout risque d'incendie dû aux étincelles.
7. Quand on ne soude pas, poser la pince à un endroit isolé de la masse. Un court-circuit accidentel peut provoquer un échauffement et un risque d'incendie.
8. S'assurer que la masse est connectée le plus près possible de la zone de travail qu'il est pratique de le faire. Si on place la masse sur la charpente de la construction ou d'autres endroits éloignés de la zone de travail, on augmente le risque de voir passer le courant de soudage par les chaînes de levage, câbles de grue, ou autres circuits. Cela peut provoquer des risques d'incendie ou d'échauffement des chaînes et des câbles jusqu'à ce qu'ils se rompent.
9. Assurer une ventilation suffisante dans la zone de soudage. Ceci est particulièrement important pour le soudage de tôles galvanisées plombées, ou cadmiées ou tout autre métal qui produit des fumées toxiques.
10. Ne pas souder en présence de vapeurs de chlore provenant d'opérations de dégraissage, nettoyage ou pistolage. La chaleur ou les rayons de l'arc peuvent réagir avec les vapeurs du solvant pour produire du phosgène (gas fortement toxique) ou autres produits irritants.
11. Pour obtenir de plus amples renseignements sur la sûreté, voir le code "Code for safety in welding and cutting" CSA Standard W 117.2-1974.

PRÉCAUTIONS DE SÛRETÉ POUR LES MACHINES À SOUDER À TRANSFORMATEUR ET À REDRESSEUR

1. Relier à la terre le châssis du poste conformément au code de l'électricité et aux recommandations du fabricant. Le dispositif de montage ou la pièce à souder doit être branché à une bonne mise à la terre.
2. Autant que possible, l'installation et l'entretien du poste seront effectués par un électricien qualifié.
3. Avant de faire des travaux à l'intérieur de poste, la débrancher à l'interrupteur à la boîte de fusibles.
4. Garder tous les couvercles et dispositifs de sûreté à leur place.

Mar '93

POWER FEED® 25M

LINCOLN
ELECTRIC

Electromagnetic Compatibility (EMC)

Conformance

Products displaying the CE mark are in conformity with European Community Council Directive of 3 May 1989 on the approximation of the laws of the Member States relating to electromagnetic compatibility (89/336/EEC). It was manufactured in conformity with a national standard that implements a harmonized standard: **EN 60974-10** Electromagnetic Compatibility (EMC) Product Standard for Arc Welding Equipment. It is for use with other Lincoln Electric equipment. It is designed for industrial and professional use.

Introduction

All electrical equipment generates small amounts of electromagnetic emission. Electrical emission may be transmitted through power lines or radiated through space, similar to a radio transmitter. When emissions are received by other equipment, electrical interference may result. Electrical emissions may affect many kinds of electrical equipment; other nearby welding equipment, radio and TV reception, numerical controlled machines, telephone systems, computers, etc. Be aware that interference may result and extra precautions may be required when a welding power source is used in a domestic establishment.

Installation and Use

The user is responsible for installing and using the welding equipment according to the manufacturer's instructions. If electromagnetic disturbances are detected then it shall be the responsibility of the user of the welding equipment to resolve the situation with the technical assistance of the manufacturer. In some cases this remedial action may be as simple as earthing (grounding) the welding circuit, see Note. In other cases it could involve construction of an electromagnetic screen enclosing the power source and the work complete with associated input filters. In all cases electromagnetic disturbances must be reduced to the point where they are no longer troublesome.

Note: The welding circuit may or may not be earthed for safety reasons according to national codes. Changing the earthing arrangements should only be authorized by a person who is competent to access whether the changes will increase the risk of injury, e.g., by allowing parallel welding current return paths which may damage the earth circuits of other equipment.

Assessment of Area

Before installing welding equipment the user shall make an assessment of potential electromagnetic problems in the surrounding area. The following shall be taken into account:

- a) other supply cables, control cables, signaling and telephone cables; above, below and adjacent to the welding equipment;
- b) radio and television transmitters and receivers;
- c) computer and other control equipment;
- d) safety critical equipment, e.g., guarding of industrial equipment;
- e) the health of the people around, e.g., the use of pacemakers and hearing aids;
- f) equipment used for calibration or measurement
- g) the immunity of other equipment in the environment. The user shall ensure that other equipment being used in the environment is compatible. This may require additional protection measures;
- h) the time of day that welding or other activities are to be carried out.

L10093 3-1-96H

POWER FEED® 25M



Electromagnetic Compatibility (EMC)

The size of the surrounding area to be considered will depend on the structure of the building and other activities that are taking place. The surrounding area may extend beyond the boundaries of the premises.

Methods of Reducing Emissions

Mains Supply

Welding equipment should be connected to the mains supply according to the manufacturer's recommendations. If interference occurs, it may be necessary to take additional precautions such as filtering of the mains supply. Consideration should be given to shielding the supply cable of permanently installed welding equipment, in metallic conduit or equivalent. Shielding should be electrically continuous throughout its length. The shielding should be connected to the welding power source so that good electrical contact is maintained between the conduit and the welding power source enclosure.

Maintenance of the Welding Equipment

The welding equipment should be routinely maintained according to the manufacturer's recommendations. All access and service doors and covers should be closed and properly fastened when the welding equipment is in operation. The welding equipment should not be modified in any way except for those changes and adjustments covered in the manufacturer's instructions. In particular, the spark gaps of arc striking and stabilizing devices should be adjusted and maintained according to the manufacturer's recommendations.

Welding Cables

The welding cables should be kept as short as possible and should be positioned close together, running at or close to floor level.

Equipotential Bonding

Bonding of all metallic components in the welding installation and adjacent to it should be considered. However, metallic components bonded to the work piece will increase the risk that the operator could receive a shock by touching these metallic components and the electrode at the same time. The operator should be insulated from all such bonded metallic components.

Earthing of the Workpiece

Where the workpiece is not bonded to earth for electrical safety, not connected to earth because of its size and position, e.g., ships hull or building steelwork, a connection bonding the workpiece to earth may reduce emissions in some, but not all instances. Care should be taken to prevent the earthing of the workpiece increasing the risk of injury to users, or damage to other electrical equipment. Where necessary, the connection of the workpiece to earth should be made by a direct connection to the workpiece, but in some countries where direct connection is not permitted, the bonding should be achieved by suitable capacitance, selected according to national regulations.

Screening and Shielding

Selective screening and shielding of other cables and equipment in the surrounding area may alleviate problems of interference. Screening of the entire welding installation may be considered for special applications. ¹

¹ Portions of the preceding text are contained in EN 60974-10: "Electromagnetic Compatibility (EMC) product standard for arc welding equipment."

I - MASTER TABLE OF CONTENTS FOR ALL SECTIONS - I

| | Page |
|---|------------------|
| Safety | .i-iv |
| Installation | Section A |
| Operation | Section B |
| Accessories | Section C |
| Maintenance | Section D |
| Theory of Operation | Section E |
| Troubleshooting and Repair | Section F |
| Electrical Diagrams | Section G |
| Parts Manual | .P-534 |

Installation **A-1**

 Technical Specifications A-2

 Safety Precautions A-3

 Location A-3

 High Frequency Protection A-3

 Digital Control Cable A-4

 Cable Connections A-4

 Control Cable Connections A-4

 Weld Cable Sizes A-5

 Coaxial Weld Cable A-5

 Electrode Polarity A-6

 Shielding Gas Connection A-6

 Changing The Drive Motor Gears A-7

 Wire Drive Configuration A-8

 Procedure to Install Drive Rolls and Wire Guides A-8

 Remote Sense Lead Specification A-9

 Loading Spools of Wire A-9/A-10

Return to Master TOC

Return to Master TOC

Return to Master TOC

Return to Master TOC

TECHNICAL SPECIFICATIONS – POWER FEED® 25M K2536-1

INPUT VOLTAGE and CURRENT

| | INPUT VOLTAGE \pm 10% | INPUT AMPERES |
|--|-------------------------|---------------|
| | 40 VDC | 4A |

RATED OUTPUT @ 104°F (40°C)

| | DUTY CYCLE | INPUT AMPERES |
|--|-------------|---------------|
| | 60% rating | 500 |
| | 100% rating | 400 |

GEARING - WIRE FEED SPEED RANGE-WIRE SIZE

| GEARING | GMAW | | FCAW | |
|-----------------------------------|-----------------------------------|-------------------------------|-----------------------------------|-------------------------------|
| | WFS RANGE | WIRE SIZES | WFS RANGE | WIRE SIZES |
| Normal Speed (factory setting) | 50 – 800 ipm (2.5 – 20.3m/min) | .023 – 1/16" (0.6 – 1.6mm) | 50 – 800 ipm (2.5 – 20.3m/min) | .030 – 5/64" (0.8 – 2.0mm) |
| Extra torque | 30 – 400 ipm (1.3 – 10.4m/min) | .023 – 1/16" (0.6 – 1.6mm) | 30 – 400 ipm (1.3 – 10.4m/min) | .030 – 3/32" (0.8 – 2.4mm) |

PHYSICAL DIMENSIONS

| HEIGHT | WIDTH | DEPTH | WEIGHT |
|---|-------------------------|--|---------------------|
| 14.5 Inches (368 mm) Handle folded down | 8.5 Inches (216 mm) | 23.5 Inches (597 mm) Memory Panel Closed | 35 lbs (15.9 kg) |

TEMPERATURE RANGE

| | |
|-------------------|--------------------------------|
| OPERATION: | -40°F to 122°F (-40°C to 50°C) |
| STORAGE: | -40°F to 185°F (-40°C to 85°C) |

SAFETY PRECAUTIONS

 **WARNING****ELECTRIC SHOCK CAN KILL.**

- Turn the input power OFF at the welding power source before installation or changing drive rolls and/or guides.
 - Do not touch electrically live parts.
 - When inching with the gun trigger, electrode and drive mechanism are "hot" to work and ground and could remain energized several seconds after the gun trigger is released.
- Welding power source must be connected to system ground per the National Electrical Code or any applicable local codes.
- Only qualified personnel should perform maintenance work.

LOCATION

For best wire feeding performance, place the POWER FEED® 25M on a stable and dry surface. Keep the wire feeder in a vertical position. Do not operate the wire feeder on an angled surface of more than 15 degrees.

Do not submerge the POWER FEED® 25M.

The POWER FEED® 25M is rated IP23 and is suitable for outdoor use.

The handle of the POWER FEED® 25M is intended for moving the wire feeder about the work place only.

When suspending a wire feeder, insulate the hanging device from the wire feeder enclosure.

HIGH FREQUENCY PROTECTION

 **CAUTION**

Locate the POWER FEED® 25M away from radio controlled machinery. The normal operation of the POWER FEED® 25M may adversely affect the operation of RF controlled equipment, which may result in bodily injury or damage to the equipment.

ELECTRODE POLARITY

The wire feeder is factory set for Electrode Positive welding. Most GMAW welding procedures use Electrode Positive welding. Most GTAW and some Innershield procedures use Electrode Negative welding.

⚠ CAUTION

When changing the electrode polarity, the weld cables must be changed at the power source studs and the DIP switch inside the wire feeder must be properly set. Operation with the DIP switch in the wrong position will cause erratic arc performance.

⚠ WARNING

ELECTRIC SHOCK CAN KILL.



- Turn the input power OFF at the welding power source before changing electrode polarity.
- Do not touch electrically live parts.
- Only qualified personnel should perform maintenance work.

| Electrode Polarity | DIP switch #7 setting |
|--------------------|-----------------------|
| Positive | OFF (Factory setting) |
| Negative | ON |

Tools required:

- 5/16" nut driver

To change the DIP switch from Electrode Polarity:

1. Turn power off at the welding power source
2. Remove the spool of wire from the feeder.
3. Remove the 4 screws holding the cover. Lift the cover out of the feeder.
4. Move DIP switch #7 on the feed head board to the appropriate position.
5. Install the cover and secure with the screws.

SHIELDING GAS CONNECTION

⚠ WARNING



CYLINDER may explode if damaged.

- Keep cylinder upright and chained to support.

- Keep cylinder away from areas where it may be damaged.
- Never lift welder with cylinder attached.
- Never allow welding electrode to touch cylinder.
- Keep cylinder away from welding or other live electrical circuits.



• BUILD UP OF SHIELDING GAS MAY HARM HEALTH OR KILL.

- Shut off shielding gas supply when not in use.
- See American National Standard Z-49.1, "Safety in Welding and Cutting" Published by the American Welding Society.

MAXIMUM INLET PRESSURE IS 100 PSI. (6.9 BAR.)

Install the shielding gas supply as follows:

1. Secure the cylinder to prevent it from falling.
2. Remove the cylinder cap. Inspect the cylinder valves and regulator for damaged threads, dirt, dust, oil or grease. Remove dust and dirt with a clean cloth. **DO NOT ATTACH THE REGULATOR IF OIL, GREASE OR DAMAGE IS PRESENT!** Inform your gas supplier of this condition. Oil or grease in the presence of high pressure oxygen is explosive.
3. Stand to one side away from the outlet and open the cylinder valve for an instant. This blows away any dust or dirt which may have accumulated in the valve outlet.
4. Attach the flow regulator to the cylinder valve and tighten the union nut(s) securely with a wrench. Note: if connecting to 100% CO₂ cylinder, insert regulator adapter between regulator and cylinder valve. If adapter is equipped with a plastic washer, be sure it is seated for connection to the CO₂ cylinder.
5. Attach one end of the inlet hose to the outlet fitting of the flow regulator. Attach the other end to the welding system shielding gas inlet. Tighten the union nuts with a wrench.
6. Before opening the cylinder valve, turn the regulator adjusting knob counterclockwise until the adjusting spring pressure is released.
7. Standing to one side, open the cylinder valve slowly a fraction of a turn. When the cylinder pressure gage stops moving, open the valve fully.
8. The flow regulator is adjustable. Adjust it to the flow rate recommended for the procedure and process being used before making a weld.

CHANGING THE DRIVE MOTOR GEAR RATIO

WARNING

- Turn off input power at the welding power source before installation or changing drive roll and/or wire guides.
 - Do not touch electrically live parts such as the wire drive or internal wiring.
- When feeding with the gun trigger, the electrode and wire drive mechanism are "hot" to work and ground and could remain energized several seconds after the gun trigger is released.
- Only qualified personnel should perform this operation.

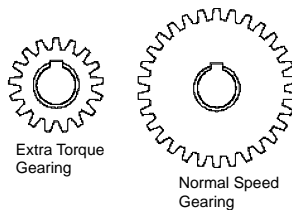
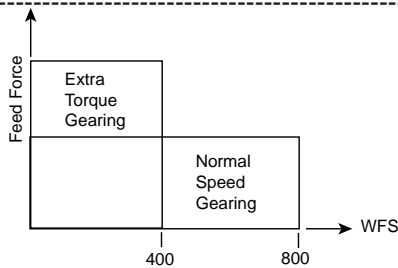

Tools required:

- 1/4" hex key wrench
- 3/4" open end wrench
- 9/16" socket and ratchet wrench
- 7/16" nut driver
- 5/16" nut driver
- Phillips screw driver

1. Remove the spool of electrode from the wire feeder.
2. Loosen the thumb screw at the wire drive and remove the welding gun.
3. Remove the outer wire guide, drive rolls and inner wire guide.
4. Use a 7/16" nut driver to remove the gear cover.
5. Use 9/16" socket and ratchet wrench to remove the lower drive roll hub retainer. Remove the lower drive roll hub.
6. With a Phillips screwdriver, remove the screw, washer and collar holding the pinion gear. Remove the pinion gear.

7. Remove the busbar by unscrewing the bolt using a 3/4" open end wrench.
8. With a 1/4" hex key wrench, loosen the socket head cap screw securing the gun bushing. Remove the gun bushing from the wire drive.
9. With a 5/16" nut driver remove the five screws securing the wire drive panel. Lift out the wire drive panel and disconnect the molex connections.
10. Using a 5/16" nut drive, remove the four screws securing the cover.
11. With a Phillips screwdriver, remove the three screws and lock washers securing the motor. Remove the motor.
12. Place the motor in the new position.
13. Assemble the three screws and lock washer holding the wire drive motor.
14. Assemble the molex connections and place the wire drive assembly inside the wire feeder. Route the gas hose through the opening in the wire drive panel.
15. Move DIP switch #8 on the Feed head board to the appropriate position.

| Gear Select | DIP Switch #8 Setting | Range |
|--------------|-----------------------|--------------|
| Normal Speed | ON | 50 – 800 ipm |
| Extra Torque | OFF | 30 – 400 ipm |

16. Place the gun bushing in the wire drive and align the threaded hole in the gun bushing with the hole in the feed plate. With a 1/4" hex key, tighten the socket head cap screw to secure the bushing in the wire drive.
17. Reassemble the busbar and tighten the mounting hardware with a 3/4" open end wrench.
18. Place the new gear on the motor shaft. Secure the gear to the motor shaft with the collar, washer and screw.
19. Reassemble the lower drive roll hub and lower drive roll hub retainer.
20. Reassemble the gear cover.
21. Reassemble the inner wire guide, drive rolls and outer wire guide.
22. Place the welding gun into the gun bushing and secure with the thumb screw.

WIRE DRIVE CONFIGURATION

(See Figure A-6)

Changing the Gun Receiver Bushing

⚠ WARNING



ELECTRIC SHOCK can kill.

- Turn the input power **OFF** at the welding power source before installation or changing drive rolls and/or guides.
- Do not touch electrically live parts.
- When inching with the gun trigger, electrode and drive mechanism are "hot" to work and ground and could remain energized several seconds after the gun trigger is released.
- Only qualified personnel should perform maintenance work.

Tools required:

- 1/4" hex key wrench.

Note: Some gun bushings do not require the use of the thumb screw.

1. Turn power off at the welding power source.
2. Remove the welding wire from the wire drive.
3. Remove the thumb screw from the wire drive.
4. Remove the welding gun from the wire drive.
5. Loosen the socket head cap screw that holds the connector bar against the gun bushing.

Important: Do not attempt to completely remove the socket head cap screw.

6. Remove the outer wire guide, and push the gun bushing out of the wire drive. Because of the precision fit, light tapping may be required to remove the gun bushing.
7. Disconnect the shielding gas hose from the gun bushing, if required.

FIGURE A-6

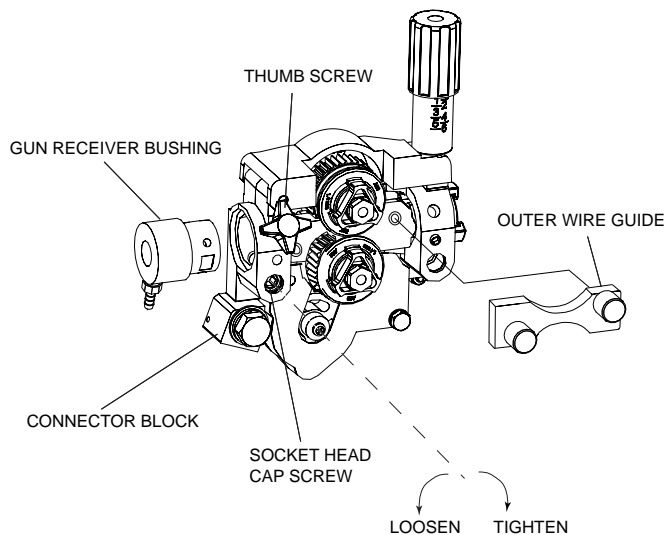

8. Connect the shielding gas hose to the new gun bushing, if required.
9. Rotate the gun bushing until the thumb screw hole aligns with the thumb screw hole in the feed plate. Slide the gun receiver bushing into the wire drive and verify the thumb screw holes are aligned.
10. Tighten the socket head cap screw.
11. Insert the welding gun into the gun bushing and tighten the thumb screw.

PROCEDURE TO INSTALL DRIVE ROLLS AND WIRE GUIDES

⚠ WARNING



- Turn the input power **OFF** at the welding power source before installation or changing drive rolls and/or guides.
- Do not touch electrically live parts.
- When inching with the gun trigger, electrode and drive mechanism are "hot" to work and ground and could remain energized several seconds after the gun trigger is released.
- Only qualified personnel should perform maintenance work.

1. Turn power off at the welding power source.
2. Release the idle roll pressure arm.
3. Remove the outer wire guide by turning the knurled thumbscrews counter-clockwise to unscrew them from the feed plate.
4. Rotate the triangular lock and remove the drive rolls.
5. Remove the inner wire guide.
6. Insert the new inner wire guide, groove side out, over the two locating pins in the feed plate.

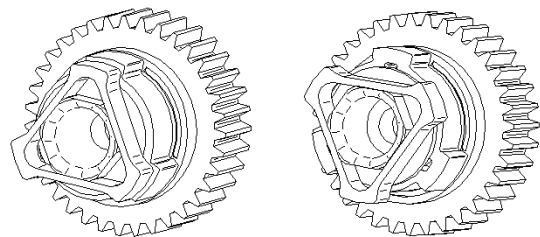

UNLOCKED
POSITION

LOCKED
POSITION

7. Install a drive roll on each hub assembly secure with the triangular lock.
8. Install the outer wire guide by aligning it with the pins and tightening the knurled thumbscrews.
9. Close the idle arm and engage the idle roll pressure arm. Adjust the pressure appropriately.

POWER FEED® 25M



REMOTE SENSE LEAD SPECIFICATIONS

Welding with Multiple Arcs:
(See Figure A.7)

Special care must be taken when more than one arc is welding simultaneously on a single part. Arc blow and arc interference may occur or be magnified. Each power source requires a work lead from the work stud to the welding fixture. Do not combine all of the work leads into one lead. Performing welding in the direction away from the work leads. Connect all of the work sense leads from each power source to the work piece at the end of the weld, such that they are out of the path of the weld current. See Figure A.7

For the best results when pulse welding, set the wire size and wire feed speed the same for all the arcs. When these parameters are identical, the pulsing frequency will be the same, helping to stabilize the arcs.

LOADING SPOOLS OF WIRE

 **WARNING**



- Keep hands, hair, clothing and tools away from rotating equipment.
- Do not wear gloves when threading wire or changing wire spool.
- Only qualified personnel should install, use or service this equipment.

Loading 10 to 15 lb. (4.5 – 6.8kg) Spools.

A K468 spindle adapter is required for loading 2" (51mm) wide spools on 2" (51mm) spindles. Use a K468 spindle adapter for loading 2-1/2" (64mm) wide spools.

1. Squeeze the release bar on the retaining collar and remove it from the spindle.
2. Place the spindle adapter on the spindle, aligning the spindle brake pin with the hole in the adapter.
3. Place the spool on the spindle and align the adapter brake tab with one of the holes in the back side of the spool. An indicator mark on the end of the spindle shows the orientation of the brake tab. Be certain the wire feeds off of the spool in the proper direction.
4. Re-install the retaining collar. Make sure that the release bar snaps out and that the retaining collar fully engages the groove on the spindle.

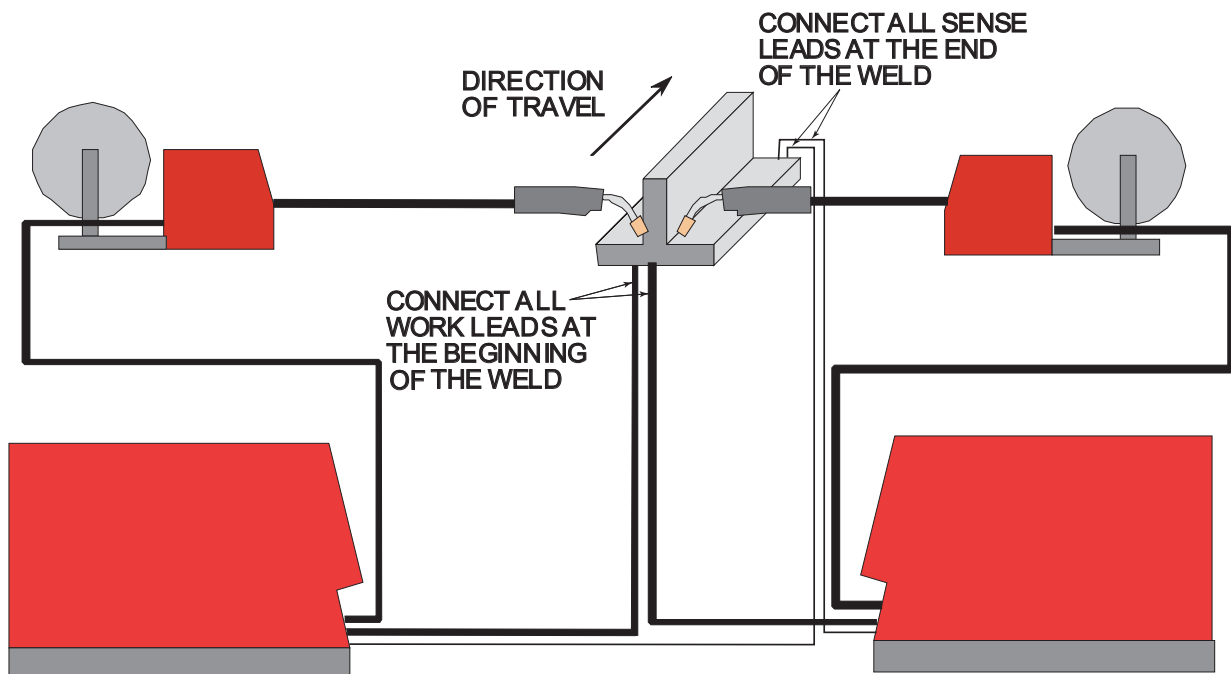
FIGURE A.7



POWER FEED® 25M

LINCOLN
ELECTRIC

TYPICAL SYSTEM CONFIGURATIONS

Standard Features

Arc Performance

- Push-Pull ready for welding aluminum with Pulse and Pulse-on-Pulse™ waveforms.
- STT™ capable when used with STT™ equipped Power Waves.
- Waveform Control Technology™ for welds with good appearance and low spatter, even when welding nickel alloys.

User Interface

- 6 memories for easily selecting procedures.
- MSP4 panel located behind the memory panel door for protection.
- Full sequence control for tailoring the weld from start to end.
- All welding controls located at the wire feeder, including process selection.

Wire Drive

Patented 2 roll drive system. MAXTRAC™ technology delivers great feeding because:

- Patent pending drive rolls improve traction on solid wire by up to 20%.
- The precision machined, rigid aluminum alloy frame results in maximum drive roll clamping pressure.
- Patented split wire guides fully support the wire and virtually eliminate birdnesting.
- No tools required to change the drive rolls and wire guides.
- Patented dual spring pressure arms have sensitivity for feeding soft wires without crushing them, and have plenty of compression force for feeding solid or stiff wires.
- All gear driven rolls for more feeding force.
- Changeable gun bushings easily accept guns from other manufacturers.

- Brass-to-brass connections between the electrode connection and the gun minimize voltage drop variations, resulting in consistent arc performance all day, every day.

- Powerful, quiet motor with integrated tachometer for accurate WFS regulation.

Extras:

- Flowmeter with gas control valve
- Push-Pull ready.
- Remote control / Foot amptrol ready.
- Internal heater for keeping condensation off of the spool of wire.
- Internal lights for illuminating the wire drive compartment.

Options

- Water cooling kit for use with water cooled guns.

Operation **B-1**

 Safety Precautions B-2

 Graphic Symbols that appear on this Machine or in this Manual B-2

 Definition of Welding Terms B-3

 General Description B-3

 Duty Cycle B-3

 Recommended Processes, Equipment Limitations, Recommended Power Sources B-4

 Case Front Controls B-5

 On-Off Switch B-6

 Making a Weld with Waveform Technology Power Sources B-7/B-24

 Set-Up Feature Menu B-25/B-28

 Procedure/Memory Panel Operaton B-29

 Internal Controls B-32

 Cold Feed / Gas Purge Switch, Light Switch, Heater Switch B-33

 2 Step - 4 Step Trigger Operation and Graphics B-33/B-38

 Rear Controls B-39

 Operation On LincNet™ Power Sources B-40

Return to Master TOC

Return to Master TOC

Return to Master TOC

Return to Master TOC

DEFINITION OF WELDING TERMS

NON-SYNERGIC WELDING MODES

- A **Non-synergic** welding mode requires all welding process variables to be set by the operator.

SYNERGIC WELDING MODES

- A **Synergic** welding mode offers the simplicity of single knob control. The machine will select the correct voltage and amperage based on the wire feed speed (WFS) set by the operator.

WFS

- Wire Feed Speed

CC

- Constant Current

CV

- Constant Voltage

GMAW

- Gas Metal Arc welding

GMAW-P

- Gas Metal Arc welding-(Pulse Arc)

GMAW-STT

- Gas Metal Arc welding-(Surface Tension Transfer)

SMAW

- Shielded Metal Arc welding

FCAW

- Flux Core Arc Welding

CAC

- Carbon Arc Cutting

CAG

- Carbon Arc Gouging

GENERAL DESCRIPTION

General Physical Description

The POWER FEED® 25M is a premium portable wire feeder for use with the Power Wave products. The wire feeder features a 2 roll MAXtrac™ drive coupled to a powerful motor for driving wire through difficult situations. The easy-to-use, MSP4 interface provides ready access to all welding modes in the Power Wave. A six button memory panel is included with the POWER FEED® 25M and allows quick recall of favorite weld procedures. All the components are packaged in an engineered aluminum case protected by replaceable skids.

The heart of the POWER FEED® 25M is the MAXtrac™ drive. The patented features on the wire drive offer tool-less changing of the drive rolls and the wire guides for quick spool changes. Plus, the drive can be configured for extra torque when feeding large diameter flux cored electrodes.

The POWER FEED® 25M continues Lincoln's lead role of environmental protection for electronics. P.C. boards are potted in epoxy and electrical connections are protected with dielectric grease. Noise suppression components protect the POWER FEED® 25M from stray signals and keep the feeder from interfering with other digital equipment.

General Functional Description

The POWER FEED® 25M is best suited for applications where quality welds are expected. Combined with a Power Wave power source, the POWER FEED® 25M is great for aluminum, nickel, alloy and other difficult to weld materials. Easy to use controls make it a great feeder for consistent results with mild steel applications too.

DUTY CYCLE

The POWER FEED® 25M is rated for 500 amps, 60% duty cycle and 400 amps, 100% duty cycle. The duty cycle is based on a 10 minute cycle.

For example, when welding at 500 amps, the POWER FEED® 25M may run 6 minutes and must idle for 4 minutes.

RECOMMENDED PROCESSES

- GMAW (CV, Synergic CV, Pulse, STT™, Power, Pulse on Pulse™, Push-Pull)
 - FCAW
 - SMAW
 - GTAW (Lift Start only)
-
- Solid wires .025" to 1/16"
 - Cored wires .035" to 5/64"
 - Cored wires .035" to 3/32" when configured for "extra torque"

EQUIPMENT LIMITATIONS

- Works only on ArcLink® or LincNet™ Power Wave® power sources.
- When operating on LincNet™ power sources, not all features are available.
- Maximum gun length is 25ft.(7.6m) for push-only systems.
- Maximum gun length is 50ft.(15.2m) for push-pull systems.
- Spool guns do not work with the POWER FEED® 25M.
- A remote control/foot amptrol and a push-pull gun may not be connected to the POWER FEED® 25M simultaneously.
- Maximum spool size is 12 in. (305 mm) diameter
- Maximum spool weight is 44 lb (20 kg).
- Maximum control cable length is 200 ft (61 m).
- Other gun bushings are required for welding guns that do not have a Magnum® (Tweco #2-#4 compatible) back end.
- No more than 2 wire feeders may be connected to one ArcLink® power source at a time.

RECOMMENDED POWER SOURCES

- Power Wave® 355M
- Power Wave® 455M
- Power Wave® 455M/STT
- Power Wave® 655/R

CASE FRONT CONTROLS (See Figure B.1)

Connector for a remote control.

- 1. Left DISPLAY window**
Shows WIRE FEED SPEED or AMPERAGE.
- 2. Left KNOB**
Adjusts values in left display.
- 3. Right Display window**
Shows VOLTAGE or TRIM.
- 4. Right Knob**
Adjusts values in the right display.
- 5. Status LED**
Illuminates a steady green when communicating to the power source properly.
- 6. IR port**
Used to transfer information to palm computers, etc.
- 7. MSP4 display window**
Shows detailed welding and diagnostic information.
- 8. Left Button**
Changes the MSP4 display to show the Weld Mode or Arc Control.
- 9. Right Button**
Changes the MSP4 display to show Start Options or End Options.
- 10. Set Knob**
Changes the value on the MSP4 display.
- 11. ON/OFF switch**
Controls power to the POWER FEED® 25M.
- 12. 5-pin connector**
Trigger connector for a push-only gun.
- 13. 6-pin connector**

- 14. 7- pin connector**
Connector for a push-pull gun.
- 15. Cover**
Covers location for optional water cooling line.
- 16. Set-Up**
Lights when feeder is set-up.
- 17. Memory Panel Door**
(See Memory Panel Operations in this Section)

FIGURE B.1

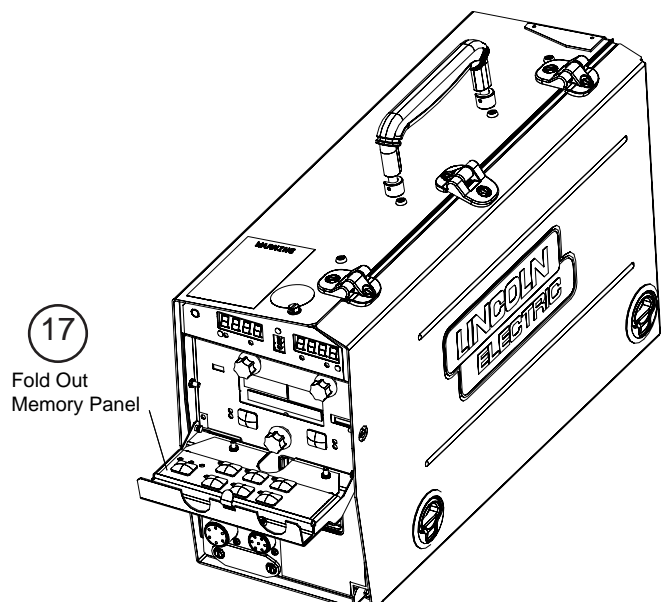
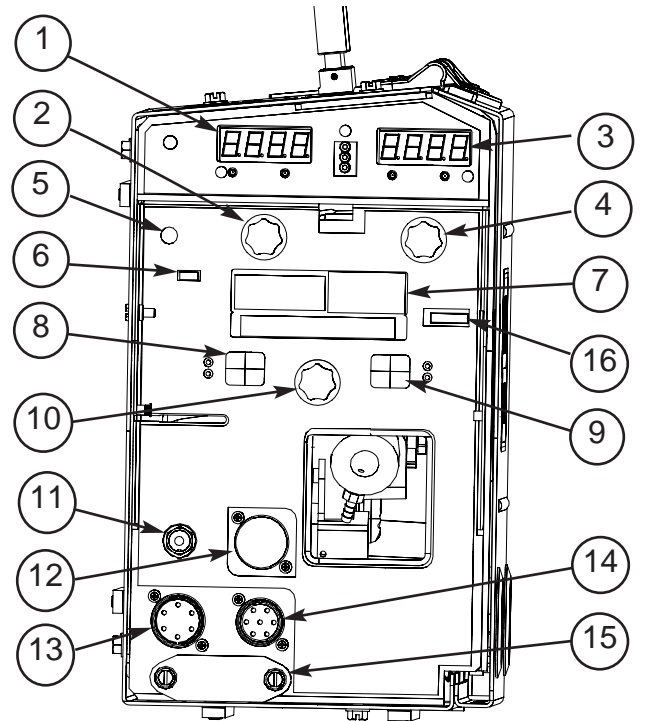

POWER FEED® 25M



11. ON-OFF SWITCH

The On-Off Switch turns the wire feeder power on and off. It does not control the power to the welding power source.



ELECTRIC SHOCK can kill.

- Turn the input power OFF at the welding power source before installation or changing drive rolls and/or guides.
- Do not touch electrically live parts.

- When inching with the gun trigger, electrode and drive mechanism are "hot" to work and ground and could remain energized several seconds after the gun trigger is released.
- Welding power source must be connected to system ground per the National Electrical Code or any applicable local codes.
- Only qualified personnel should perform maintenance work.

STATUS LED
(See Table B.1)

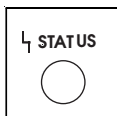

The status LED indicates system status. Normal operation is a steady green light.

Note: During normal power-up, the LED may flash red and/or green as the equipment performs self tests.

TABLE B.1

| LED condition | Definition |
|--|--|
| Steady green | System okay. The power source and wire feeder are communicating normally. |
| Blinking green. | Occurs during a reset and indicates the power source is identifying each component in the system. This is normal for up to 15 seconds after power-up, or if the system configuration is changed during operation. |
| Blinking green, fast | Indicates that one or more pieces of ArcLink equipment are not mapping properly. Check the DIP switch setting on the wire feeders. |
| Blinking green followed by blinking red. | Non-recoverable system fault. If the power source or wire feeder status LED is flashing any combination of red and green, errors are present in the system. Count the error code before the machine is turned off-see below. Error codes are detailed in the Troubleshooting Section E. Individual code digits are flashed in red with a long pause between digits. After each error code the LED will flash green and codes will repeat. There may be more than one error code indicated. Record the red flash count (error code) for reference before turning unit off. To clear the error, turn the power source OFF, and then back ON to reset. See Troubleshooting Section E. |

SMAW (Stick) Welding Display

FIGURE B.3

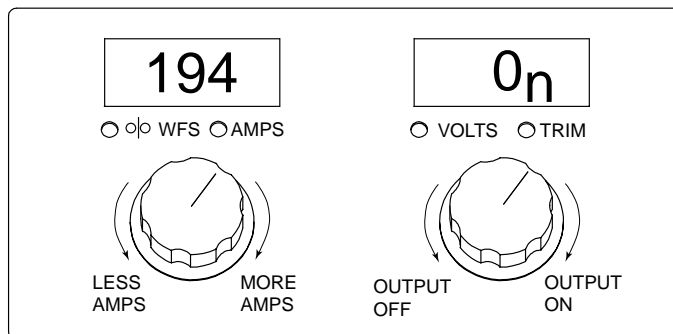

MSP4 OPERATION

| CC STICK MODES | | |
|----------------|-------------|------|
| PROCESS | | MODE |
| Stick | Soft(7018) | 1 |
| Stick | Crisp(6010) | 2 |

| START OPTIONS | |
|-----------------|---|
| START TIME: | FUNCTION |
| 0 to 10 seconds | If no remote control is installed, this control sets the time for the weld output to ramp up or down from a preset Start current to the preset Weld current. Use the WFS/AMP knob to adjust Start current while the Start Options LED is displayed. |

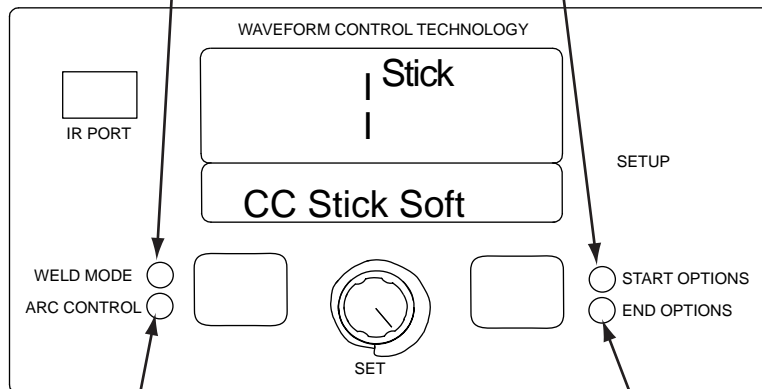

| ARC CONTROL | |
|-----------------------------|---|
| ARC FORCE | DESCRIPTION |
| (Soft)-10.0 to (Crisp)+10.0 | Arc Force adjusts the short circuit current for a soft arc, or for a forceful, driving arc. It helps to prevent sticking and shorting of organic coated electrodes, particularly globular transfer types such as stainless and low hydrogen. Arc Force is especially effective for root pass on pipe with stainless electrode and helps to minimize spatter for certain electrodes and procedure as with low hydrogen, etc. |

END OPTIONS
No arc ending options are active for SMAW (Stick) welding modes.

Return to Section TOC
 Return to Section TOC
 Return to Section TOC
 Return to Master TOC
 Return to Master TOC
 Return to Master TOC

NON-SYNERGIC GMAW AND FCAW WELDING

(See Figure B.4)

Non-synergic GMAW and FCAW welding mimics the welding controls of traditional welding power sources. Voltage and WFS are set as independent variables.

Three non-synergic welding modes are available.

| Description | Mode | Used for: |
|-------------------|------|---|
| GMAW, Standard CV | 5 | Best for traditional MIG welding. |
| GMAW, Power | 40 | Specialized mode for short arc welding and CV aluminum welding. |
| FCAW | 6 | Best for cored electrodes, such as Innershield™ and Outershield™. |

FIGURE B.4

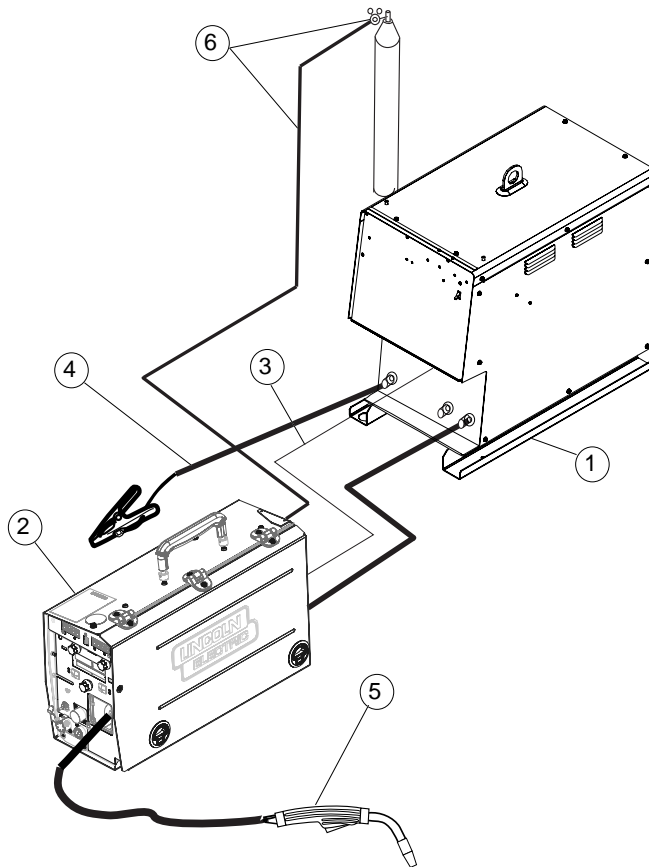

| | | |
|---|-------------------------------|---|
| 1 | K2368-1 K2202-1 K2203-1 | Power Wave 355M Power Wave 455M Power Wave 455M/STT |
| 2 | K2230-1 | Power Feed 10M, Bench Model |
| | K2234-1 | Power Feed 10M Dual, Bench Model |
| | K2536-1 | Power Feed 25M |
| | KP1696-xx, KP1697-xx | Drive Roll Kit, 2 Roll Feeder |
| | KP1505-xx, KP1507-xx | Drive Roll Kit, 4 Roll Feeder |
| 3 | K1543-xx | Digital Control Cable |
| 4 | K1842-xx | Weld Power Cable, Lug to Lug |
| | K910-xx | Ground Clamp |
| 5 | See Magnum Literature | MIG gun |
| 6 | K586-1 | Deluxe Regulator for Mixed Shielding Gases |
| | | Shielding Gas Hose |

POWER FEED® 25M



Return to Section TOC

Return to Section TOC

Return to Section TOC

Return to Section TOC

Return to Master TOC

Return to Master TOC

Return to Master TOC

Return to Master TOC

GMAW (MIG) SYNERGIC WELDING

Synergic welding allows for easy procedure setting. The WFS and Voltage change together to maintain an optimal arc length. During synergic welding, when the WFS (left) knob is rotated, the voltage is adjusted accordingly to maintain a similar arc length.

FIGURE B.5

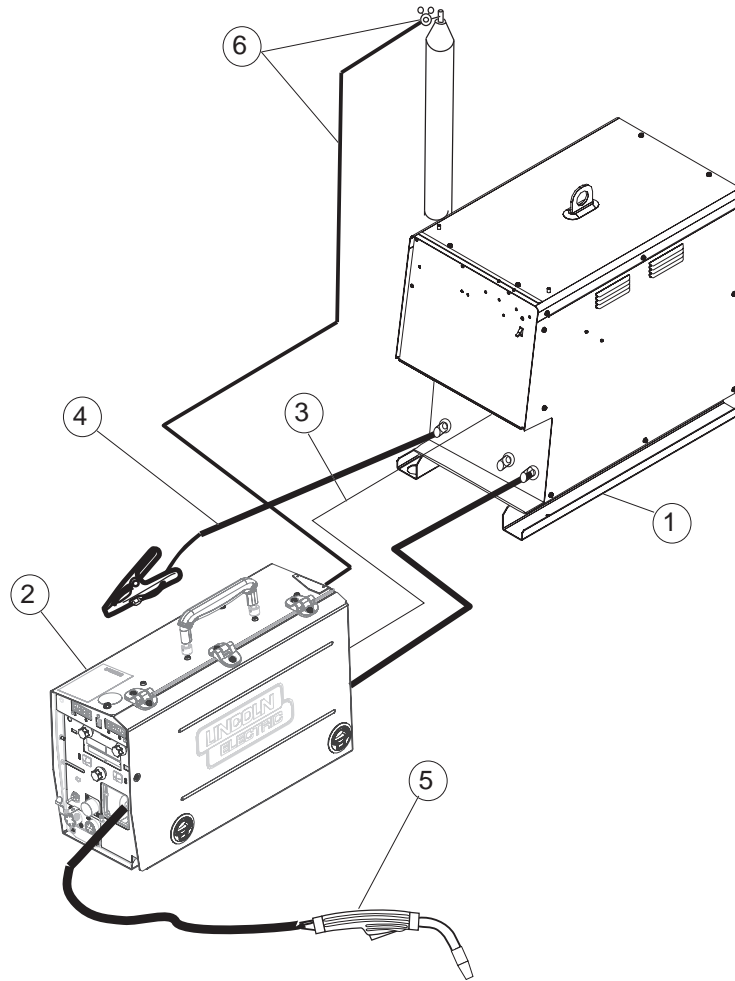

| | | |
|---|-------------------------|--|
| 1 | K2368-1 | Power Wave® 355M |
| | K2202-1 | Power Wave® 455M |
| | K2203-1 | Power Wave® 455M/STT |
| 2 | K2230-1 | Power Feed® 10M, Bench Model |
| | K2234-1 | Power Feed® 10M Dual, Bench Model |
| | K2536-1 | Power Feed® 25M |
| | KP1696-xx, KP1697-xx | Drive Roll Kit, 2 Roll Feeder |
| | KP1505-xx, KP1507-xx | Drive Roll Kit, 4 Roll Feeder |
| 3 | K1543-xx | Digital Control Cable |
| 4 | K1842-xx | Weld Power Cable, Lug to Lug |
| | K910-xx | Ground Clamp |
| 5 | See Magnum Literature | MIG gun |
| 6 | K586-1 | Deluxe Regulator for Mixed Shielding Gases |
| | | Shielding Gas Hose |

POWER FEED® 25M



GMAW (MIG) Synergic Welding Display

Synergic CV programs feature an ideal voltage best suited for most procedures. Use this voltage as a starting point and adjust if needed for personal preferences.

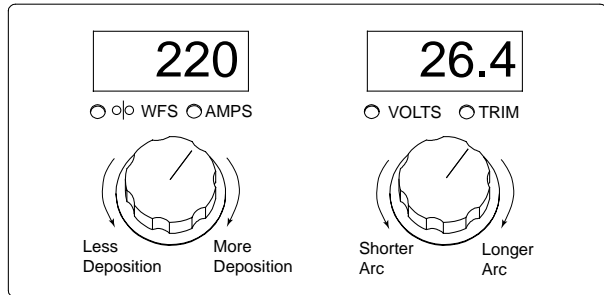

SYNERGIC CV VOLTAGE DISPLAY

When the voltage knob is rotated, the display will show an upper or lower bar indicating if the voltage is above or below the ideal voltage.

- Preset voltage above ideal voltage. (upper bar displayed)



- Preset voltage at ideal voltage. (no bar displayed)



- Preset voltage below ideal voltage. (lower bar displayed)



MSP4 OPERATION

| WELD MODE | | WIRE SIZE | | | |
|-------------------|-----------------------|-----------|-------|-------|-------|
| ELECTRODE AND GAS | | 0.030 | 0.035 | 0.045 | 0.052 |
| Steel | CO ₂ | --- | 10 | 20 | 24 |
| Steel | Ar(Mix) | 94 | 11 | 21 | 25 |
| Stainless | Ar(Mix) | 61 | 31 | 41 | --- |
| Stainless | Ar/He/CO ₂ | 63 | 33 | 43 | --- |
| Aluminum 4043 | Ar | --- | 148 | 71 | --- |
| Aluminum 5356 | Ar | --- | 151 | 75 | --- |

| START OPTIONS | |
|---------------------------------------|---|
| EFFECT / RANGE | DESCRIPTION |
| Preflow Time 0 - 10 seconds | Adjusts the time that shielding gas flows after the trigger is pulled and prior to feeding. |
| Run-in WFS: Off, 50 to 150 in/min. | Run-in sets the wire feed speed from the time the trigger is pulled until an arc is established. |
| Start Procedure | The Start Procedure controls the WFS, Volts at a specified time at the beginning of the weld. During the start time, the machine will ramp up or down from the Start Procedure to the preset Welding Procedure. |



| ARC CONTROL | |
|----------------------------------|--|
| EFFECT / RANGE | DESCRIPTION |
| PINCH EFFECT (-10.0 to +10.0) | Pinch controls the arc characteristics when short-arc welding. |

| END OPTIONS | |
|----------------------------------|--|
| EFFECT / RANGE | DESCRIPTION |
| Postflow Time 0 to 10 seconds | Adjusts the time that shielding gas flows after the welding output turns off. |
| Burnback: 0 to .25 Seconds | The burnback time is the amount of time that the weld output continues after the wire stops feeding. It prevents the wire from sticking in the puddle and prepares the end of the wire for the next arc start. |
| Crater Procedure | Crater Procedure controls the WFS and volts for a specified time at the end of the weld after the trigger is released. During the Crater time, the machine will ramp up or down from the Weld Procedure to the Crater Procedure. |

STAINLESS STEEL GMAW (MIG)WELDING

FIGURE B.8

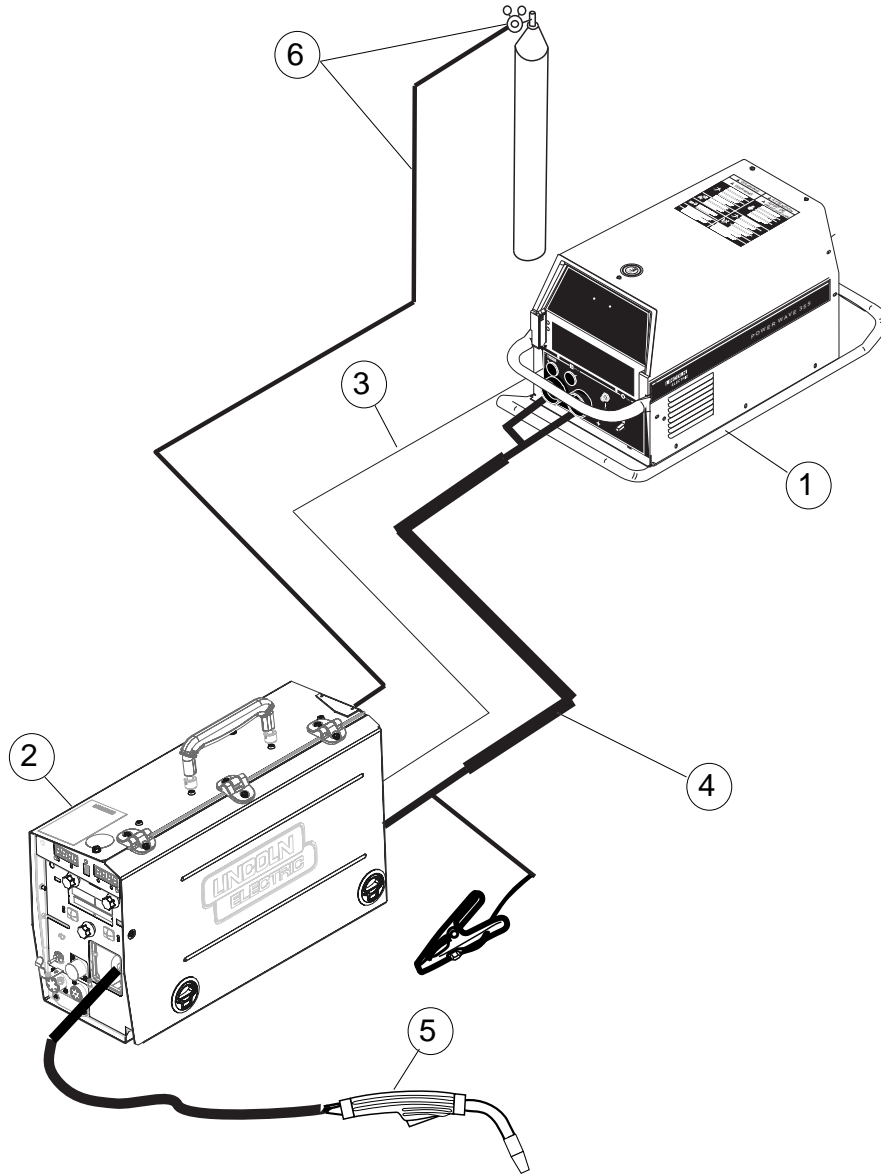

| | | |
|---|-------------------------------|--|
| 1 | K2368-1 K2202-1 K2203-1 | Power Wave® 355M Power Wave® 455M Power Wave® 455M/STT |
| 2 | K2230-1 | POWER FEED® 10M, Bench Model |
| | K2234-1 | POWER FEED® 10M Dual, Bench Model |
| | K2536-1 | POWER FEED® 25M |
| | KP1696-xx, KP1697-xx | Drive Roll Kit, 2 Roll Feeder |
| | KP1505-xx, KP1507-xx | Drive Roll Kit, 4 Roll Feeder |
| 3 | K1543-xx | Digital Control Cable |
| 4 | K1796-xx, K2593-xx | Coaxial Weld Power Cable, Lug to Lug |
| | K910-xx | Ground Clamp |
| 5 | See Magnum Literature | MIG gun |
| 6 | K586-1 | Deluxe Regulator for Mixed Shielding Gases Shielding Gas Hose |

POWER FEED® 25M



Return to Section TOC
Return to Master TOC

Steel and Stainless GMAW-P (Pulsed MIG) Display

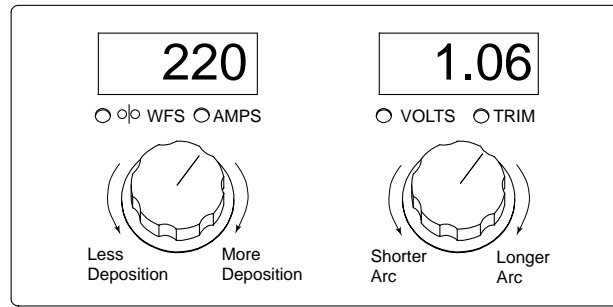

MSP4 OPERATION

| WELD MODE | | WIRE SIZE | | | |
|-------------------|-----------------------|-----------|-------|-------|-------|
| ELECTRODE AND GAS | | 0.030 | 0.035 | 0.045 | 0.052 |
| Steel(Crisp) | Ar(Mix) | 95 | 12 | 22 | 201 |
| Steel(Soft) | Ar(Mix) | --- | 14 | 19 | 28 |
| Stainless | Ar/ CO ₂ | 66 | 36 | 46 | --- |
| Stainless | Ar/ CO ₂ | 62 | 32 | 42 | --- |
| Stainless | Ar/He/CO ₂ | --- | 34 | 44 | --- |

| START OPTIONS | |
|---------------------------------------|--|
| PREFLOW TIME | DESCRIPTION |
| 0 - 10 seconds | Adjusts the time that shielding gas flows after the trigger is pulled and prior to feeding wire. |
| RUN-IN WFS: Off, 50 to 150 in/min. | Run-in sets the wire feed speed from the time the trigger is pulled until an arc is established. |
| Start Procedure | The Start Procedure controls the WFS, Trim at a specified time at the beginning of the weld. During the start time, the machine will ramp up or down from the Start Procedure to the preset Welding Procedure. |



| ARC CONTROL | |
|-----------------------------|--|
| ARC FOCUS | DESCRIPTION |
| -10.0 (SOFT to 10.0 (STIFF) | Arc Focus adjusts the arc from a wide, soft arc good for out of position work to a narrow, stiff arc preferred for faster travel speeds. The pulse frequency is lower with a soft arc and higher with a stiff arc. |

| END OPTIONS | |
|-----------------------------------|---|
| EFFECT / RANGE | FUNCTION |
| Postflow Time: 0 to 10 seconds | Adjusts the time that shielding gas flows after the welding output turns off. |
| Burnback: 0 to .25 Seconds | The burnback time is the amount of time that the weld output continues after the wire stops feeding. It prevents the wire from sticking in the puddle and prepares the end of the wire for the next arc start. |
| Crater Procedure | Crater Procedure controls the WFS and Trim for a specified time at the end of the weld after the trigger is released. During the Crater time, the machine will ramp up or down from the Weld Procedure to the Crater Procedure. |

[Return to Section TOC](#) | [Return to Master TOC](#)

ALUMINUM SYNERGIC GMAW-P (PULSED MIG) AND GMAW-PP (PULSE ON PULSE) WELDING

The POWER FEED® 25M and Power Wave welding power source combine to readily produce top quality aluminum welds with excellent appearance, little spatter and good bead shape. Push-pull guns are available for consistent feeding when welding a long distance away from the wire feeder.

Pulse-on-Pulse Welding

The POWER FEED® system offers both traditional pulse and Pulse-on-Pulse™. Pulse-on-Pulse (GMAW-PP) is an exclusive waveform for aluminum welding. Use it to make welds with a "stacked dime" appearance, similar to GTAW welds.

FIGURE B.9



The pulsing frequency is adjustable. Changing the frequency modulation (or arc control) of the waveform changes the ripple spacing. Faster travel speeds may be achieved by using higher values of frequency modulation.

FIGURE B.10

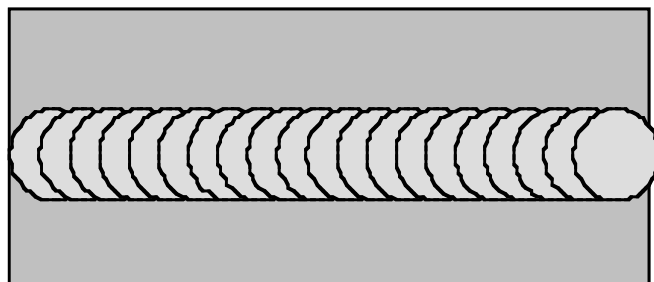

Frequency Modulation = -10
Wide weld and ripple spacing, slow travel speed.

FIGURE B.11

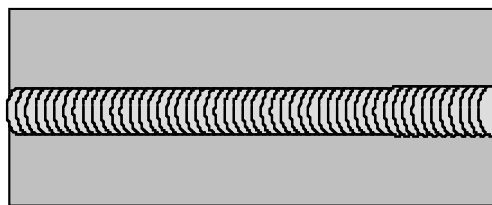

Frequency Modulation = 10
Narrow weld and ripple spacing, fast travel speed.

Return to Section TOC

Return to Section TOC

Return to Section TOC

Return to Section TOC

Return to Master TOC

Return to Master TOC

Return to Master TOC

Return to Master TOC

ALUMINUM GMAW-P AND GMAW-PP WELDING

FIGURE B.14

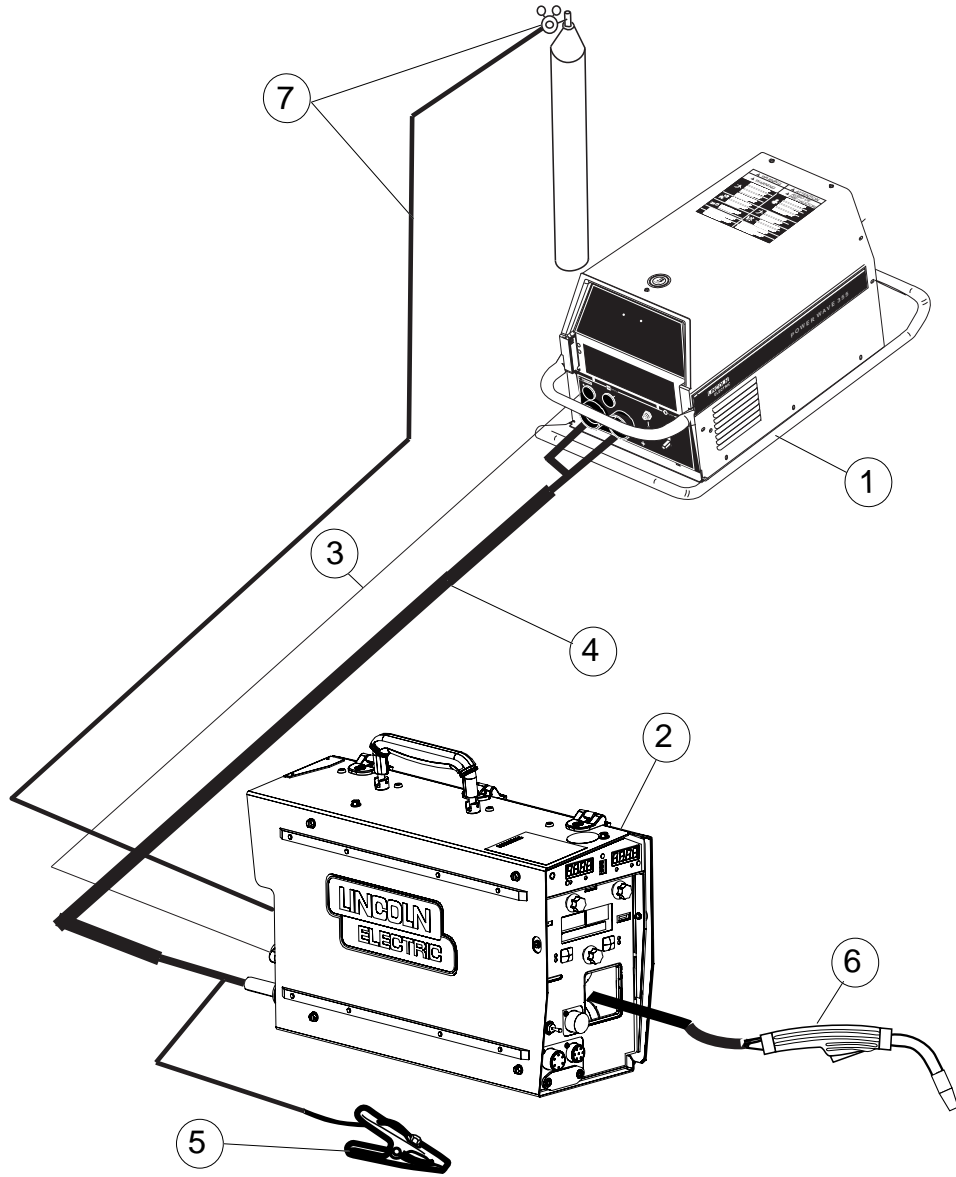

| | | |
|---|-------------------------------|---|
| 1 | K2368-1 K2202-1 K2203-1 | Power Wave® 355M Power Wave® 455M Power Wave® 455M/STT |
| 2 | K2230-1 | POWER FEED® 10M, Bench Model Requires K1634-1 Spool cover |
| | K2234-1 | POWER FEED® 10M Dual, Bench Model Requires K1634-1 Spool cover |
| | K2536-1 | POWER FEED® 25M |
| | KP1695-xx KP1507-xx | Drive Roll Kit, 2 Roll Feeder Drive Roll Kit, 4 Roll Feeder |
| 3 | K1543-xx | Digital Control Cable |
| 4 | K1796-xx, K2593-xx | Coaxial Weld Power Cable, Lug to Lug |
| 5 | K910-xx | Ground Clamp |
| 6 | K2447-xx | Python Plus Gun, Air cooled |
| 7 | K586-1 | Deluxe Regulator for Mixed Shielding Gases Shielding Gas Hose |

POWER FEED® 25M



Return to Section TOC
Return to Master TOC

Aluminum Pulse and Pulse-On-Pulse (Synergic) Weld Display

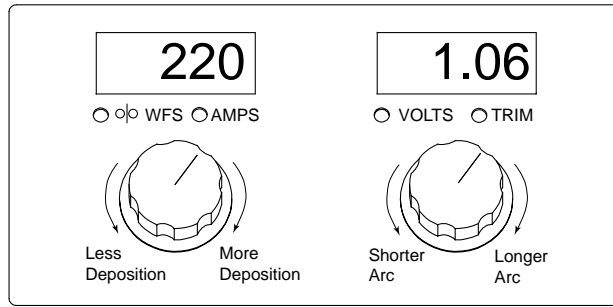

MSP4 OPERATION

| WELD MODES | | | |
|-------------------|-----------|------|------|
| ELECTRODE AND GAS | WIRE SIZE | | |
| | 0.035 | 3/64 | 1/16 |
| ALUMINUM 4043 Ar | 149 | 72 | 74 |
| ALUMINUM 4043 Ar | 98 | 99 | 100 |
| ALUMINUM 5356 Ar | 152 | 76 | 78 |
| ALUMINUM 5356 Ar | 101 | 102 | 103 |

| START OPTIONS | |
|---------------------------------------|--|
| PREFLOW TIME | DESCRIPTION |
| 0 - 10 seconds | Adjusts the time that shielding gas flows after the trigger is pulled and prior to feeding wire. |
| RUN-IN WFS: Off, 50 to 150 in/min. | Run-in sets the wire feed speed from the time the trigger is pulled until an arc is established. |
| Start Procedure | The Start Procedure controls the WFS. Trim at a specified time at the beginning of the weld. During the start time, the machine will ramp up or down from the Start Procedure to the preset Welding Procedure. |

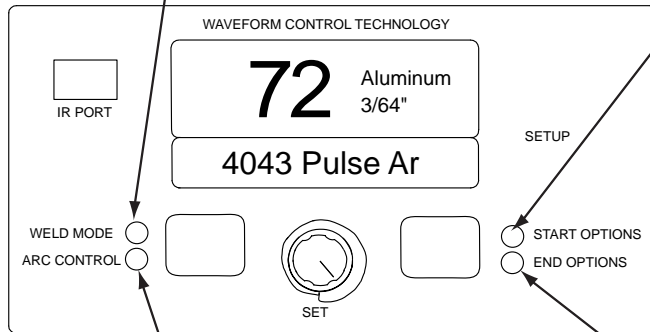

| ARC CONTROL | |
|---|---|
| PULSE FREQUENCY: | DESCRIPTION |
| (Low)-10.0 to (High)+10.0 | For Pulse modes, Arc Control changes the pulsing frequency. When the frequency changes, the Power Wave system automatically adjusts the background current to maintain a similar heat input into the weld. Low frequencies give more control over the puddle and high frequencies minimize spatter. |
| PULSE-ON-PULSE FREQ. MODULATION (Low)-10.0 to (High)+10.0 | For Pulse -On-Pulse modes, Arc controls changes the frequency modulation. The frequency modulation controls the spacing of the ripples in the weld. Use low values for slow travel speeds and wide welds, and high values for fast travel speeds and narrower welds. |

| END OPTIONS | |
|-----------------------------------|---|
| EFFECT / RANGE | FUNCTION |
| Postflow Time: 0 to 10 seconds | Adjusts the time that shielding gas flows after the welding output turns off. |
| Burnback: 0 to .25 Seconds | The burnback time is the amount of time that the weld output continues after the wire stops feeding. It prevents the wire from sticking in the puddle and prepares the end of the wire for the next arc start. |
| Crater Procedure | Crater Procedure controls the WFS and Trim for a specified time at the end of the weld after the trigger is released. During the Crater time, the machine will ramp up or down from the Weld Procedure to the Crater Procedure. |

[Return to Section TOC](#) | [Return to Section TOC](#) | [Return to Section TOC](#) | [Return to Master TOC](#) | [Return to Master TOC](#) | [Return to Master TOC](#)

GMAW-STT™

Waveform Control Technology™ maximizes the ability to modify the arc for the perfect weld. When **STT™** welding, the parameters to control are:

- Wire Feed Speed - sets the deposition rate.
- Peak Current - controls the arc length.
- Background Current - regulates the bead contour.
- Tail-out - provides additional power in the arc.

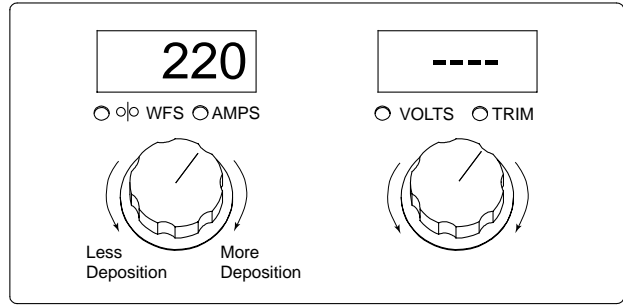

There is no Voltage control when **STT™** welding.

MSP4 OPERATION

| WELD MODES | | | |
|--|-----------|-------|-------|
| ELECTRODE AND GAS | WIRE SIZE | | |
| | 0.035 | 0.045 | 0.052 |
| STEEL CO ₂ Ar/CO ₂ | 110 | 126 | 126 |
| STAINLESS He/Ar/CO ₂ | 110 | 126 | 126 |
| (with Hot Start) | | | |
| STEEL CO ₂ Ar/CO ₂ | 123 | 124 | 124 |
| STAINLESS He/Ar/CO ₂ | 123 | 124 | 124 |
| (SYNERGIC STT) | | | |
| STEEL CO ₂ | 111 | 117 | 120 |
| STEEL AR/CO ₂ | 112 | 118 | 121 |
| STAINLESS He/Ar/CO ₂ | 127 | 129 | --- |
| STAINLESS Ar/CO ₂ | 131 | 133 | --- |
| SYNERGIC STT, OPEN ROOT | | | |
| STEEL CO ₂ | 113 | 119 | 122 |
| STAINLESS He/Ar/CO ₂ | 135 | 137 | --- |



| START OPTIONS | |
|---------------------------------------|--|
| PREFLOW TIME | FUNCTION |
| 0 - 10 seconds | Adjusts the time that shielding gas flows after the trigger is pulled and prior to feeding wire. |
| RUN-IN WFS: Off, 50 to 150 in/min. | Run-in sets the wire feed speed from the time the trigger is pulled until an arc is established. |
| Start Procedure | The Start Procedure is not commonly used with STT procedures. |

| ARC CONTROL | |
|------------------------------|--|
| EFFECT / RANGE | DESCRIPTION |
| PEAK CURRENT | Peak Current acts similar to an arc pinch control. Peak Current sets the arc length and promotes good fusion. Higher peak current levels will cause the arc to broaden momentarily while increasing arc length. If set too high, globular transfer may occur. Setting it too low may cause instability and wire stubbing. Best practice is to adjust for minimum spatter and puddle agitation. |
| BACKGROUND CURRENT | Background Current controls the overall heat input in the weld. |
| TAIL OUT (STT II MODES ONLY) | Tail out provides additional power without the molten droplet becoming too large. Increase as necessary to add heat input without increasing arc length. Often this results in faster travel speeds. Note that as tail out increases, the peak current and/or background current may need to be reduced. |

| END OPTIONS | |
|-----------------------------------|--|
| PARAMETER RANGE | FUNCTION |
| Postflow Time: 0 to 10 seconds | Adjusts the time that shielding gas flows after the welding output turns off. |
| Burnback: 0 to .25 Seconds | The burnback time is the amount of time that the weld output continues after the wire stops feeding. It prevents the wire from sticking in the puddle and prepares the end of the wire for the next arc start. |
| Crater Procedure | Crater is not commonly used in STT weld procedures. |

POWER FEED® 25M



Return to Section TOC

Return to Master TOC

PEAK CURRENT (Figure B.16)

Peak current controls the arc length, which also affects the shape of the root. When using 100% CO₂, the peak current will be higher than when welding with blended shielded gases. A longer arc length is required with CO₂ to reduce spatter.

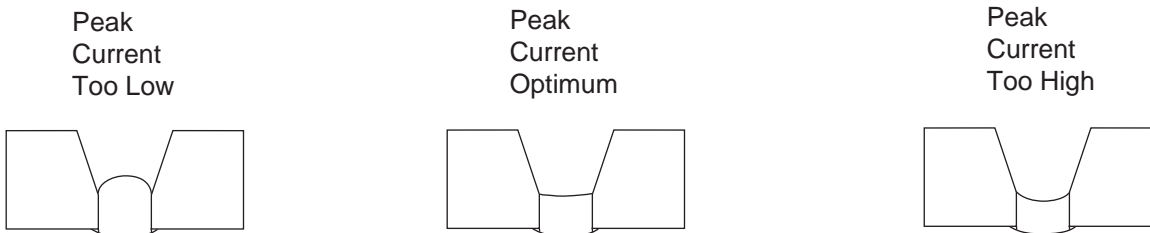
FIGURE B.16**BACKGROUND CURRENT (Figure B.17)**

Background current adjusts the overall heat input into the weld. Changing the background current changes the shape of the back bead. 100% CO₂ requires less background current than when welding with blended shielding gases.

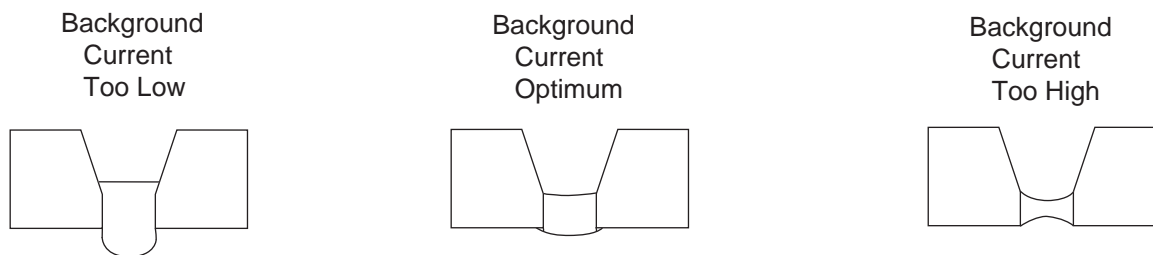
FIGURE B.17**TAILOUT**

Tailout provides additional heat into the weld without increasing the arc length or the droplet size. Higher tailout values improve wetting and may give faster travel speeds.

GTAW (TIG) WELDING

The POWER FEED® / Power Wave system is excellent for Touch Start TIG welding.

The system supports TIG torches with or without gas control valves. TIG torches with gas control valves connect directly to the gas flow regulator. For TIG torches without gas control valves, connect the output gas hose on the wire feeder to the TIG torch gas hose.

The wire feeder gas solenoid may be enabled or disabled by parameter P.8 in the set-up menu found in this operations section.

| Touch Start TIG Weld Sequence | No Foot / Hand Amptrol | With Foot / Hand Amptrol |
|--|--|---|
| TIG torches without built-in Gas Valves. | <ol style="list-style-type: none"> 1. Adjust the arc amperage with the left knob on the display panel. 2. Turn the right knob on the display panel until the Output Control is ON. Gas will start to flow. 3. Touch the tungsten to the work piece. 4. Lift the tungsten to create an arc and weld. 5. Stop welding by turning the Output Control to OFF, or by pulling away the tungsten from the work. 6. Gas flow will continue for a short time and then shut-off. | <ol style="list-style-type: none"> 1. Adjust the maximum arc amperage with the left knob on the display panel. 2. Touch the tungsten to the work piece. 3. Press the foot pedal or slide the hand amptrol a slight amount. Gas will start to flow. 4. Lift the tungsten to create an arc. 5. Regulate the arc current with the foot pedal or hand amptrol. 6. Stop welding by releasing the foot pedal or hand amptrol, or by pulling the tungsten away from the work. 7. Gas will continue for a short time and then shut-off. |
| TIG torches with built-in Gas Valves. | <ol style="list-style-type: none"> 1. Adjust the arc amperage with the left knob on the display panel. 2. Turn the right knob on the display panel until the Output Control is ON. 3. Open the gas valve on the TIG torch. 4. Touch the tungsten to the work piece. 5. Lift the tungsten to create an arc and weld. 6. Stop welding by turning the Output Control to OFF, or by pulling away the tungsten from the work. 7. Close the gas valve on the TIG torch. | <ol style="list-style-type: none"> 1. Adjust the maximum arc amperage with the left knob on the display panel. 2. Touch the tungsten to the work piece. 3. Press the foot pedal or slide the hand amptrol a slight amount. 4. Open the gas valve on the TIG torch. 5. Lift the tungsten to create an arc. 6. Regulate the arc current with the foot pedal or hand amptrol. 7. Stop welding by releasing the foot pedal or hand amptrol, or by pulling the tungsten away from the work. 8. Close the gas valve on the TIG torch. |

GTAW (TIG) WELDING

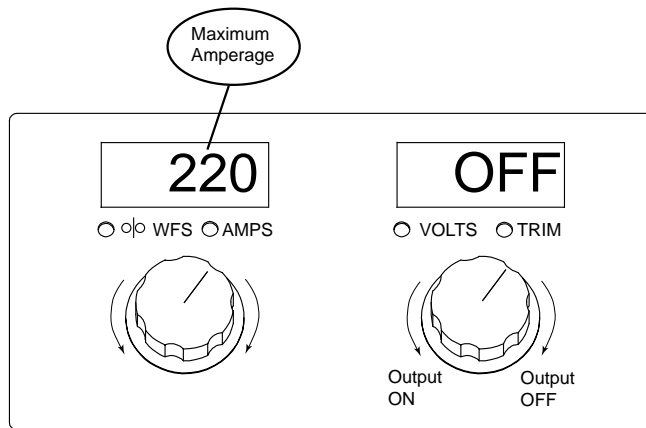
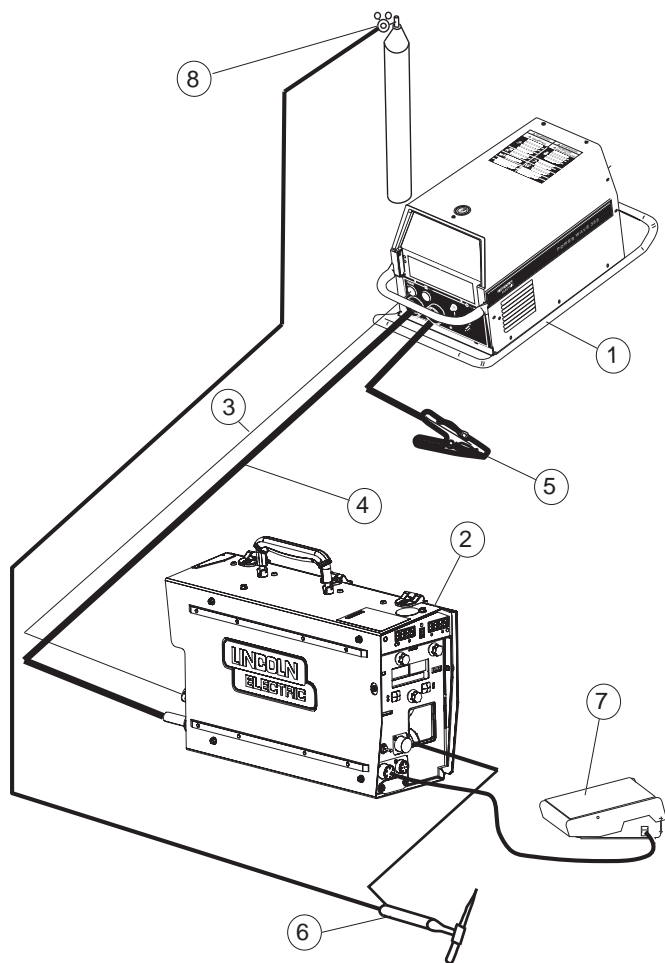

| WELD MODE | |
|-------------|---|
| MODE | |
| TOUCH START | 3 |

| START OPTIONS | |
|--|--|
| START PROCEDURE | |
| The Start Procedure controls the Amperage at a fixed level for the set amount of time. | |

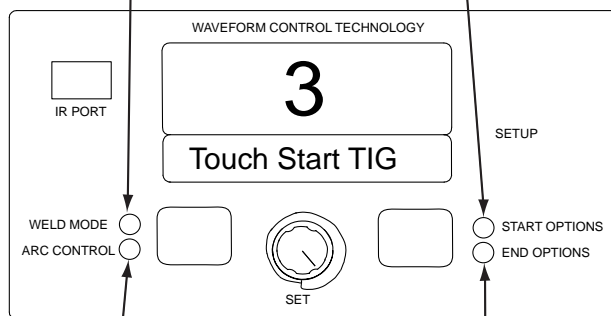

ARC CONTROL
No Arc Controls are active for Touch Start TIG.

END OPTIONS
No Arc End Options are active for Touch Start TIG

| | | |
|---|--------------------|---|
| 1 | K2368-1 | Power Wave® 355M |
| | K2202-1 | Power Wave® 455M |
| | K2203-1 | Power Wave® 455M/STT™ |
| 2 | K2230-1 | POWER FEED® 10M, Bench Model |
| | K2234-1 | POWER FEED® 10M Dual, Bench Model |
| | K2536-1 | POWER FEED® 25M |
| 3 | K1543-xx | Digital Control Cable |
| 4 | | Electrode Cable |
| 5 | K910-xx | Ground Clamp |
| 6 | K1782-xx, K1783-xx | PTA-17, PTA-26 TIG torch (shown with valve) |
| 7 | K870 | Foot Amptrol |
| 8 | 3100211 | Harris Argon Flow Regulator |

SET-UP FEATURES MENU

The Setup Menu gives access to the set-up configuration. Stored in the set-up configuration are user parameters that generally need to be set only at installation. The parameters are grouped as follows:

- P.1 through P.99 Unsecured Parameters (always adjustable)
- P.101 through P.199 Diagnostic Parameters (always read only)
- P.501 through P.599 Secured Parameters (accessible only through a p.c. or palm application.)

To access the set-up menu, press the right and left buttons of the MSP4 panel simultaneously. Note that the set-up menu cannot be accessed if the system is welding, or if there is a fault (The status LED is not solid green).

Change the value of the blinking parameter by rotating the SET knob.

After changing a parameter it is necessary to press the right hand button to save the new setting. Pressing the left button will cancel the change.

To exit the set-up menu at any time, press the right and left buttons of the MSP4 panel simultaneously. Alternately, 1 minute of inactivity will also exit the set-up menu.

The following list includes all possible parameters in ArcLink® equipment. Not all of the parameters listed may appear for your system. Refer to Table B.1 for active parameters.

TABLE B.1

| Unsecured Parameters | | POWER FEED® 10M (All Models) | POWER FEED® 25M | POWER FEED® 10A |
|-----------------------|--------------------------|---------------------------------|--------------------|--------------------|
| PARAMETER | DESCRIPTION | | | |
| P.0 | Exit set-up menu | ⌀ | ⌀ | ⌀ |
| P.1 | WFS Units | ⌀ | ⌀ | ⌀ |
| P.2 | Arc Display Mode | ⌀ | ⌀ | ⌀ |
| P.4 | Trigger Memory Recall | ⌀ | ⌀ | |
| P.5 | Trigger Procedure Change | ⌀ | ⌀ | |
| P.6 | Stall Factor Adjustment | ⌀ | ⌀ | |
| P.7 | Gun Offset Adjustment | ⌀ | ⌀ | |
| P.8 | TIG Gas Control | ⌀ | ⌀ | |
| P.11 | Set Timers | | | ⌀ |
| P.12 | Travel Options | | | ⌀ |
| P.13 | Adjust Arc Force | | | ⌀ |
| P.80 | Sense From Studs | ⌀ | ⌀ | |
| P.99 | Show Test Modes | ⌀ | ⌀ | ⌀ |
| Diagnostic Parameters | | | | |
| P.100 | View Diagnostics | ⌀ | ⌀ | ⌀ |
| P.101 | View Event Logs | ⌀ | ⌀ | ⌀ |
| P.102 | View Fatal Logs | ⌀ | ⌀ | ⌀ |
| P.103 | View Software Version | ⌀ | ⌀ | ⌀ |
| P.104 | View Hardware Version | ⌀ | ⌀ | ⌀ |
| P.105 | View Welding Software | ⌀ | ⌀ | ⌀ |
| P.106 | View Ethernet IP Address | ⌀ | ⌀ | ⌀ |
| P.107 | View Power Source Type | ⌀ | ⌀ | ⌀ |

| | |
|---|---|
| <p>P.0 Press the left button to exit the set-up menu.</p> <p>P.1 WFS units Metric = m/min wire feed speed units English = in/min wire feed speed units (default)</p> <p>P.2 Arc Display Mode Amps = The left display shows Amperage while welding. (default) WFS = The left display shows Wire Feed Speed while welding.</p> <p>P.4 Trigger Memory Recall Enable = Selecting memories 2 through 6 with quick trigger pulls is enabled when the optional dual procedure/memory panel is installed. To recall a memory with the gun trigger, quickly pull and release the trigger the number of times that correspond to the memory number. For example, to recall memory 3, quickly pull and release the trigger 3 times. Trigger memory recall can only be performed when the system is not welding. Disable = Memory selection is performed only by the buttons on the optional dual procedure/memory panel. (default)</p> <p>P.5 Procedure Change Method (Three Settings) In order for any of these procedure change methods to function, the "A-Gun-B" switch must be on the "Gun" position.</p> <ol style="list-style-type: none"> 1. "External Switch" (the default value), the machine will only change the selected procedure when the procedure select digital input changes state. 2. "Quick Trigger" (the optional value 1), the machine will only change the selected procedure when the trigger is released and quickly re-pulled while welding in 2-step. Enable=Allows switching between procedure A and procedure B while welding. The exception is that the procedure select digital input is no longer recognized. 3. "Integral Trigger Procedure" (the optional value 2), the machine will only change the selected procedure when the procedure select digital input changes state. Machine operation is similar to the "External Switch" selection except that additional logic prevents procedure A from being re-selected when the trigger is quickly and completely released at step 2 of the 4-step weld sequence. This selection is intended to be used when a MIG gun with an integral procedure select switch built into the trigger (e.g.DS400) is used with 4-step welding. | <p>P.6 Push Pull Gun, Stall Factor Adjustment. The stall factor controls the stall torque of the push motor when using a push-pull gun. The wire feeder is factory set to not stall unless there is a large resistance to feeding wire. The stall factor can be reduced to stall more easily and possibly prevent bird nesting.</p> <p>However, low stall factors can cause motor stalling while welding which results in the wire burning back to the tip. If you are experiencing bird nests, check for other feeding problems before adjusting the stall factor.</p> <p>Default value for the stall factor is 75, with a range of 5 - 100.</p> <p>To change the stall factor:</p> <ul style="list-style-type: none"> • Use the VOLTS/TRIM knob to adjust the stall factor. Increasing the stall factor raises the motor torque and decreasing the stall factor lowers the motor torque. Do not increase the stall factor more than necessary. A high stall factor may increase the occurrence of bird nesting and a low stall factor may cause the wire to burn back to the tip. • Press the right hand button to save the new setting. <p>P.7 Push Pull Gun, Gun Offset Adjustment The push-pull gun offset calibration adjusts the wire feed speed calibration of the pull motor. The procedure should only be performed when other possible corrections do not solve the push-pull feeding problems. A rpm meter is required to perform the pull gun motor offset calibration.</p> <p>To perform the calibration procedure:</p> <ul style="list-style-type: none"> • Release the pressure arm on both the pull and push wire drives. • Set the wire feed speed to 200 ipm. • Remove wire from the pull wire drive. • Hold the rpm meter to the drive roll in the pull gun. • Pull the trigger on the push-pull gun. • Measure the rpm of the pull motor. The rpm should be between 115 and 125 rpm. If necessary, decrease the calibration setting to slow the pull motor, or increase the calibration setting to speed up the motor. The calibration range is -30 to +30, with 0 as the default value. • Press the right hand button to save the new setting. |
|---|---|

- P.8 TIG Gas Control (Two Settings)
1. "**Valve (manual)**", the internal solenoid will not actuate while TIG welding, gas flow is manually controlled by an external valve.
 2. "**Solenoid (auto)**", the internal gas solenoid will turn on and off automatically while TIG welding as follows:
 - Preflow time will not be accessible from the MSP4.
 - Postflow time will be available in the MSP4 "End Options" and have a range of OFF to 10.0 seconds.
 - The postflow time value is maintained when switching between MIG and TIG modes.
 - When machine output on/off is controlled via the right encoder, gas flow will not start until the tungsten touches, the work piece, gas flow will stop after the postflow time when the arc is broken.
 - When machine output on/off is controlled via an arc start switch or foot Amptrol, gas will begin flowing when the output is turned on and stop flowing after the postflow period after the output is turned off.
- P.11 Set Timers
- This menu is used to adjust timer values for Upslope, Downslope and Restrike. Press the right button to enter the Set Timer menu. Rotate the knob to select the timer to adjust and then press the right button. Adjust the value of the timer by rotating the knob. Press the left MSP4 button to set the value and exit. Continue to adjust other timers as necessary, and then press the left button to exit the Set Timer menu.
- P.12 Travel Options
- This menu is used to change the travel options for a travel carriage, including starting and ending functions. The right MSP4 button to enter the Travel Options menu and rotate the encoder to select either starting or ending options. Press the right MSP4 button to select the option. Press the left MSP4 button to set the value and exit. Rotate the encoder to select other options, or press the left MSP4 button to exit the menu.
- P.13 Adjust Arc Force
- Use this menu to adjust Arc Force values for Start, Weld and Crater. Press the right MSP4 button to enter the menu and rotate the knob to choose either Start, Weld or Crater. Press the right MSP4 button and then rotate the knob to the desired value. Press the left MSP4 button to set the value and exit. Continue to adjust Arc Force for other states, and then press the left MSP4 button to exit the menu.
- P.80 Sense From Studs (two settings)
1. "**False**", the voltage sense lead is automatically selected based on the DIP switch configuration and the selected weld mode. This is the default value that is used every time the machine is powered up. Note that setting P.80 to "**False**" does not preclude voltage sensing from the studs if studs sensing is specified by the selected weld mode (for example stick and TIG weld modes will still sense voltage at the studs).
 2. "**True**", voltage sensing is forced to "studs" regardless of the DIP switch configuration and selected weld mode. Setting P.80 to "**True**" should only be done for troubleshooting purposes. P.80 will automatically be set back to "**False**" the next time the equipment is powered up or can be manually changed back to "**False**" via the setup menu.
- In order to control the welding arc, the power source continually monitors arc current and arc voltage. Arc current is measured internal to the power source. Arc voltage can be measured as follows:
- Voltage internal to the power source ("studs")
 - Voltage at the wire feeder ("67" lead)
 - Voltage at a user-wired sense lead ("21" lead)
- Remote voltage sensing (anything other than "studs") is used to obtain a more accurate voltage measurement since the sense lead is closer to the arc. Remote voltage sensing can involve external wiring and DIP switch configuration, there is a potential for incorrect voltage measurement which can lead to poor arc control or wire burn back.

- P.99 Show Test Modes
Many weld tables include special modes for testing and servicing the welding system. Set this parameter to YES to show all test modes.
- When the power source is turned off, the Show Test Modes parameter automatically reverts back to "NO".
- P.100 View Diagnostics
Diagnostics are only used for servicing the Power Wave system.
Yes = Shows P.101 through P.500 in the SETUP menu.
No = Only P.0 through P.100 are shown in the SETUP menu.
- P.101 Event Logs
Press the right MSP4 button to view the Event Logs. Rotate the encoder to select the object to read and then press the right MSP4 button. Various software information will appear about key system events. Press the left MSP4 button to exit.
- P.102 Fatal Logs
Press the right MSP4 button to view the Fatal Logs. Rotate the encoder to select the module to read and then press the right MSP4 button. Various software information will appear about critical module actions. Press the left MSP4 button to exit.
- P.103 Software Version
Press the right MSP4 button to view the software loaded into each module (p.c. board). Rotate the encoder to select the module to read and then press the right MSP4 button. The panel will display the main software version loaded into the module. Press the left MSP4 button to exit.
- P.104 Hardware Version
Press the right MSP4 button to view the hardware version of each module (p.c. board). Rotate the encoder to select the module to read and then press the right MSP4 button. The panel will display the main hardware version loaded into the module. Press the left MSP4 button to exit.
- P.105 Welding Software
Press the right MSP4 button to view the welding software version inside the power source. Press the left MSP4 button to exit.
- P.106 Ethernet IP Address
Press the right MSP4 button to view the IP address of the Ethernet board. If no Ethernet Board is installed, the display shows "No Enet Found." Press the left MSP4 button to exit.
- P.107 Power Source
Press the right MSP4 button to view the type of power source connected to the control box. Press the left MSP4 button to exit.

PROCEDURE/MEMORY PANEL OPERATION

The Dual Procedure/Memory Panel performs three functions:

- **Weld procedure selection**
- **Memory save and recall**
- **Limits setting**

There are two procedure memories (A and B) and six user memories (1-6).

Procedure Memory vs. User Memory

Procedure memory is used while welding. Changes to the weld procedure (WFS, voltage, arc control, etc.) immediately change the contents inside the selected procedure memory.

User memories work by copying the weld procedure from one of the six memories into either the A or B procedure. Weld procedures are saved into the memories only when the operator chooses.

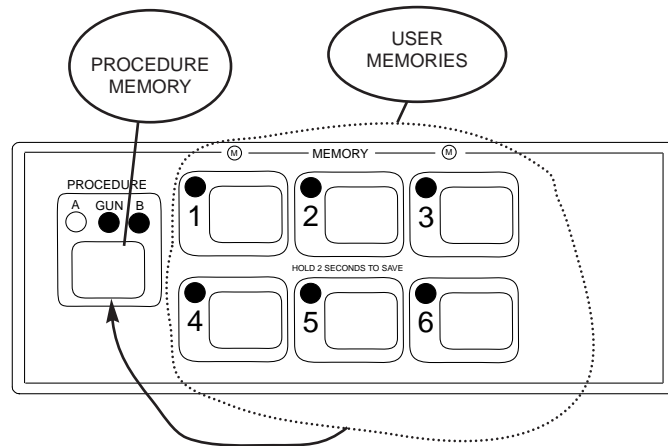

Using Procedure Memories

Procedure memories can be selected by choosing either "A" or "B" procedure directly with the memory panel, or by selecting "GUN" and using a dual procedure gun to select between procedure "A" and "B". When selecting procedures with the gun switch, "A" or "B" will flash to show which procedure is active.

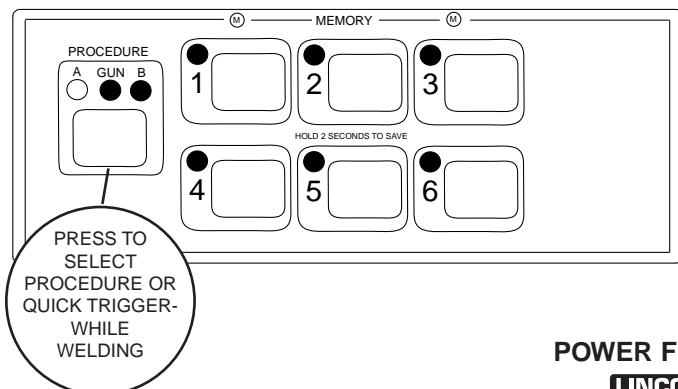

USER MEMORIES

Recall a memory with memory buttons

To recall a user a memory, press one of the six user memory buttons. The memory is recalled when the button is released. Do not hold the button for more than two seconds when recalling a user memory.

Recall a memory with the gun trigger

If desired, memories 2 through 6 can be recalled with the gun trigger. For example, to recall memory 3, quickly pull and release the gun trigger 3 times without welding.

Note: the POWER FEED® Wire Feeders are factory set with this feature disabled. Use the SETUP menu and change P.4 to enable memory recall with the gun trigger.

Save a memory with memory buttons

To save a memory, press and hold the desired memory button for two seconds. When the button is initially pressed, the corresponding LED will illuminate. After two seconds, the LED will turn off. Do not hold the button for more than 5 seconds when saving a user memory.

Note that memories may be locked using Weld Manager from a P.C. or Palm application to prevent accidental overwrite of the memories. If an attempt is made to save a memory when memory saving is locked, the message "Memory save is Disabled!" will appear briefly in the MSP4 display.

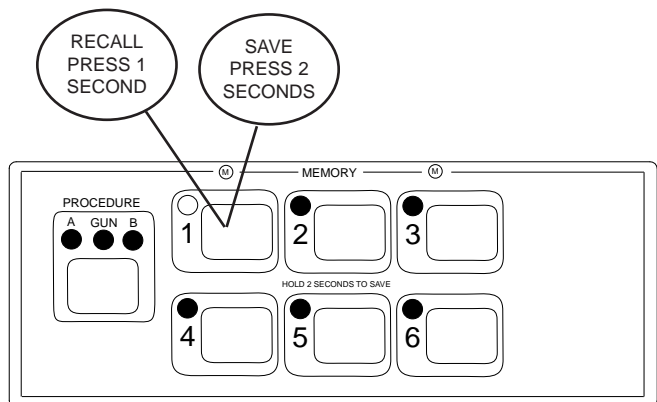

LIMITS

Limits allow the welder to adjust the welding procedure only within a defined range.

Each user memory may have a different set of limits. For example, memory 1 can be set to limit the WFS to 200 through 300 in/min, and memory 2 can be set to limit the WFS to 275 through 310 in/min, while memory 3 may not have any WFS limits.

Parameters are always constrained by machine limits. When memory limits are enabled, the parameter will flash whenever an attempt is made to exceed the memory limit value. The parameter will not flash if an attempt is made to exceed the machine limit.

Machine limits are:

| Parameter | Range | Units |
|-----------------|--|---------------------|
| Wire Feed Speed | Weld mode dependent and gear box ratio dependent | in/min |
| Voltage | Weld mode dependent | Volts |
| Trim | 0.50 to 1.50 | -- |
| Arc Control | -10.0 to 10.0 | Weld mode dependent |
| Preflow | 0.0 to 2.5 | Seconds |
| Start Time | 0.0 to 10.0 | Seconds |
| Run-In WFS | Off, 50 to 150 | in/min |
| Crater Time | 0.0 to 10.0 | Seconds |
| Burnback Time | 0.00 to 0.25 | Seconds |
| Postflow Time | 0.0 to 10.0 | Seconds |

Limits may be set for:

- Wire Feed Speed/Amperage
- Voltage/Trim
- Arc Control
- Preflow Time
- Run-In Speed
- Start Wire Feed Speed
- Start Voltage/Trim
- Start Time
- Burnback Time
- Crater Wire Feed Speed
- Crater Voltage/Trim
- Crater Time
- Postflow Time

Weld modes cannot be selected through the Limits Setup menu, and must be chosen and saved to memory before entering the Limits Setup Menu.

To set limits, press the desired memory button 1-6 and hold for 5 seconds. Release the memory button when the LED begins to blink rapidly and the MSP4 displays "Memory X Set Limits" as shown below.

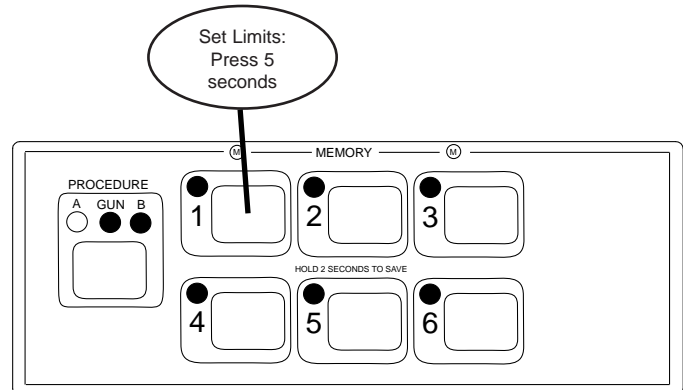

MSP4 DISPLAY

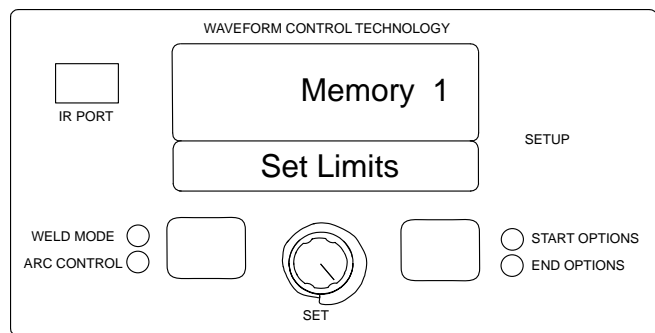

Four items show on the MSP4 panel.

- Memory Value
- High Limit
- Low Limit
- Parameter Name

One of these items will flash to indicate which item will change when the MSP4 encoder is rotated. Press the right button on the MSP4 panel to select the item to change.

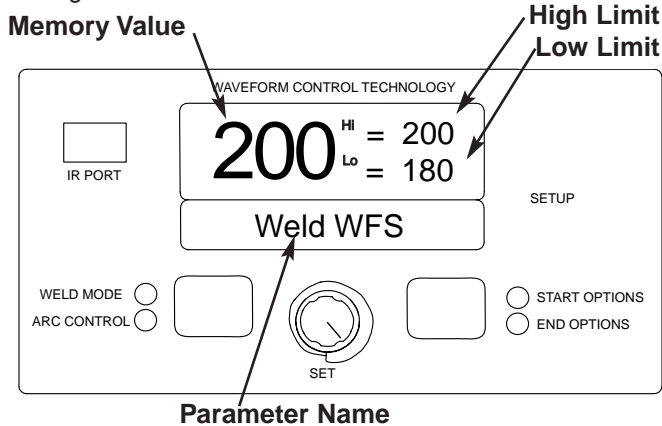

The memory value must always be less than or equal to the high limit, and greater than or equal to the low limit.

After setting limits, press the memory button with the flashing LED. The MSP4 will ask to save or discard the limit changes just made. Press the left MSP4 button (YES) to save and enable the limits and exit. Press the right MSP4 button (NO) to exit and leave limits unchanged.

Enabling/Disabling Limits

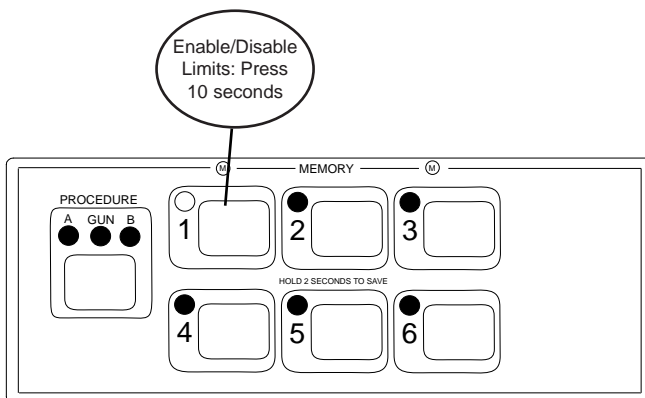

The Limits Setup menu shows a list of all parameters available for the weld mode stored in the memory chosen. For example, if limits are being set for a stick (SMAW) mode, parameters such as Run-in WFS and Postflow will not appear.

To lock a parameter to a specific value that cannot be changed, set the high and low limits to the same value.

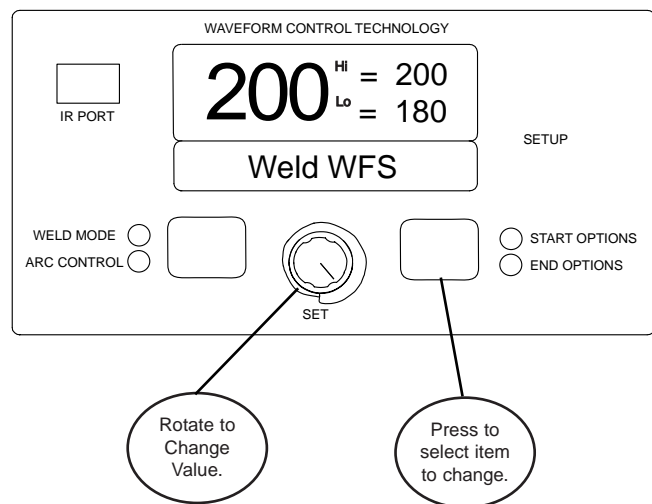

Limits for each memory may be enabled or disabled by pressing and hold the appropriate memory button for 10 seconds. Release the memory button when the MSP4 display shows the following:

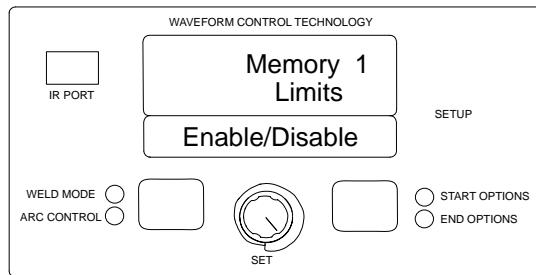

Press the left MSP4 button (YES) to enable limits or the right MSP4 button (NO) to disable limits. Disabling limits does not change any limits values that may have been previously set.

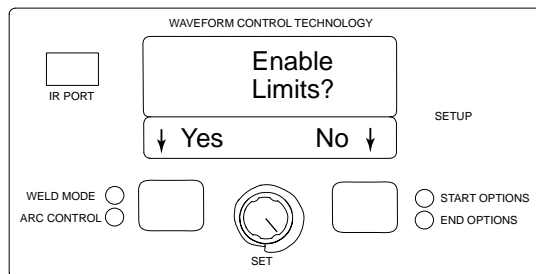

Return to Section TOC

Return to Section TOC

Return to Section TOC

Return to Section TOC

Return to Master TOC

Return to Master TOC

Return to Master TOC

Return to Master TOC

INTERNAL CONTROLS

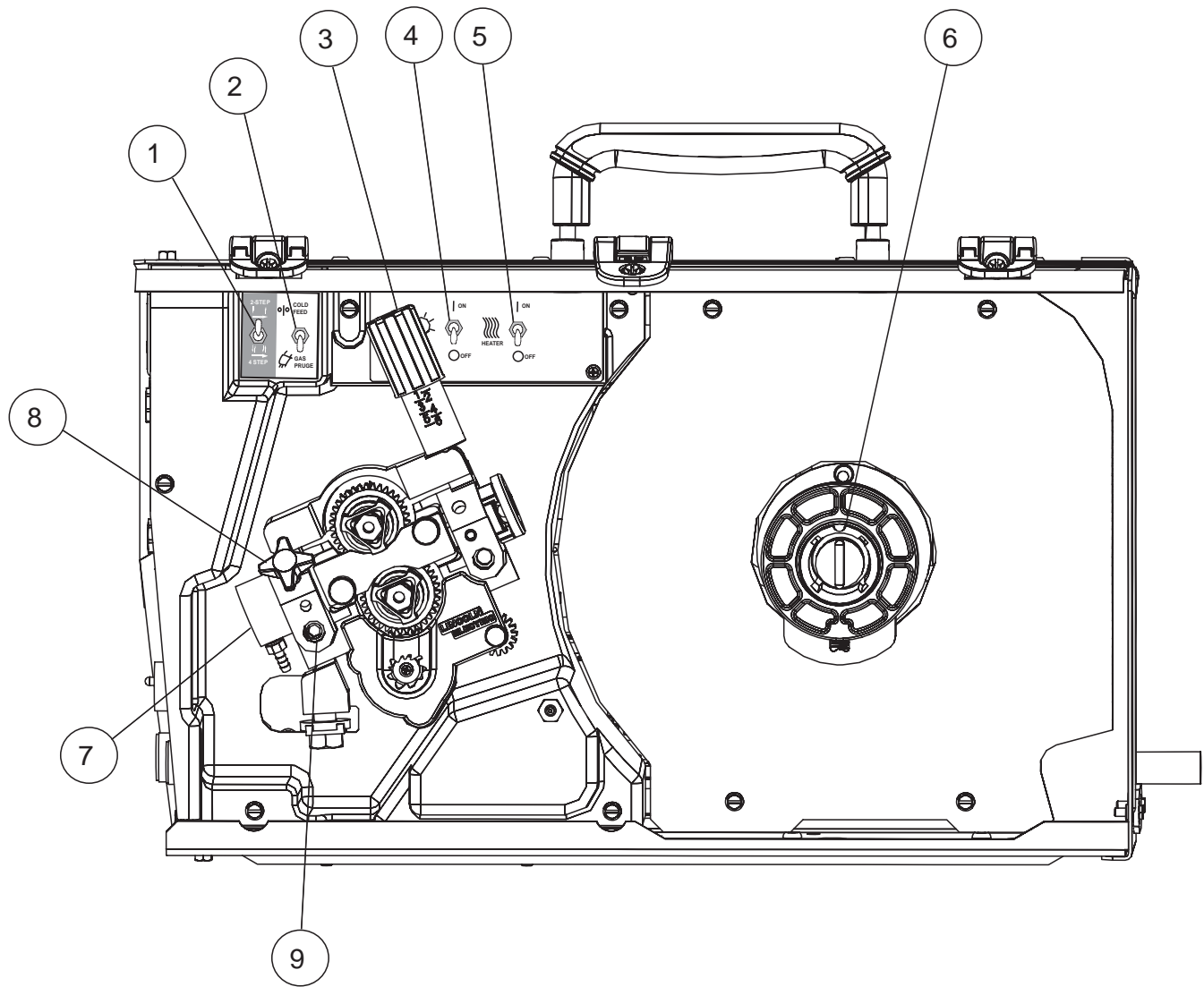

| ITEM | DESCRIPTION |
|------|--|
| 1 | 2 Step / 4 Step Trigger Switch |
| 2 | Cold Feed / Purge Switch |
| 3 | Wire Drive Pressure Arm |
| 4 | Internal Light Switch |
| 5 | Internal Heater Switch |
| 6 | Spindle Brake |
| 7 | Gun Bushing |
| 8 | Thumb Screw for securing the welding Gun |
| 9 | Socket Head Cap Screw for securing the Gun Bushing to the Electrode Connection |

POWER FEED® 25M



NOTE: All switches described on this page will function only when power source is **ON**.

COLD FEED/GAS PURGE SWITCH

Cold Feed and Gas Purge are combined into a single spring centered toggle switch.

To activate Cold Feeding, hold the switch in the **UP** position. The wire drive will feed electrode but neither the power source nor the gas solenoid will be energized. Adjust the speed of cold feeding by rotating the WFS knob. Cold feeding, or "cold inching" the electrode is useful for threading the electrode through the gun.

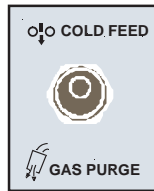

Hold with toggle switch in the **DOWN** position to activate Gas Purge and let the shielding gas flow. The gas solenoid valve will energize but neither the power source output nor the drive motor will be turned on. The Gas Purge switch is useful for setting the proper flow rate of shielding gas. Flow meters should always be adjusted while the shielding gas is flowing.

LIGHT SWITCH

Turn the internal light switch **ON** to illuminate the inside of the POWER FEED® 25M.

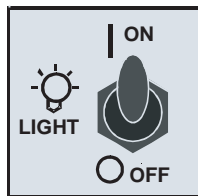

HEATER SWITCH

Turn the heater switch **ON** to warm the inside of the POWER FEED® 25M. The heater is useful for reducing condensation build-up on the spool of wire.

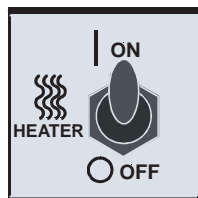

2 STEP - 4 STEP - TRIGGER OPERATION

The 2 Step - 4 Step switch changes the function of the gun trigger. 2 Step trigger operation switches the welding output ON-OFF in direct response to the trigger. 4 Step trigger operation provides 'trigger interlock' capability and gives the ability to control the amount of time spent in the arc start and arc crater steps.

Place the toggle switch in the **UP** position for 4 Step operation and in the **DOWN** position for 2 Step operation.

The 2 Step - 4 Step trigger has no effect when welding with SMAW or CAG procedures.

2 Step Trigger

2 Step trigger operation is the most common. When the gun trigger is pulled, the welding system (power source and wire feeder) cycles through the arc starting sequence and into the main welding parameters. The welding system will continue to weld as long as the gun trigger is activated. Once the trigger is released, the welding system cycles through the arc ending steps.

4 Step Trigger

4 Step trigger operation gives the welder additional control in the welding sequence. 4 step trigger allows the welder to choose the arc start, weld and arc end time. It may also be set-up to work as a trigger interlock.

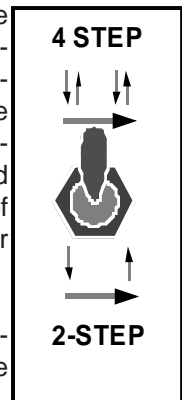

EXAMPLE 1 - 2 STEP TRIGGER: Simple operation
 The simplest trigger operation occurs with a 2 Step trigger and the Start, Crater and Burnback functions all set to OFF. (See Figure B.19)

For this sequence,

PREFLOW:

Shielding gas begins to flow immediately when the gun trigger is pulled.

STRIKE:

After preflow time expires, the power source regulates to the welding output and wire is advanced towards the work piece at the strike Run-In WFS. If an arc is not established within 1.5 seconds, the wire feed speed will jump to the welding wire feed speed.

WELD:

The power source output and the wire feed speed continue at the weld settings for as long as the trigger is pulled.

POSTFLOW: As soon as the trigger is released, the power source output and the wire feed speed are turned OFF. Shielding gas continues until the post flow timer expires.

FIGURE B.19

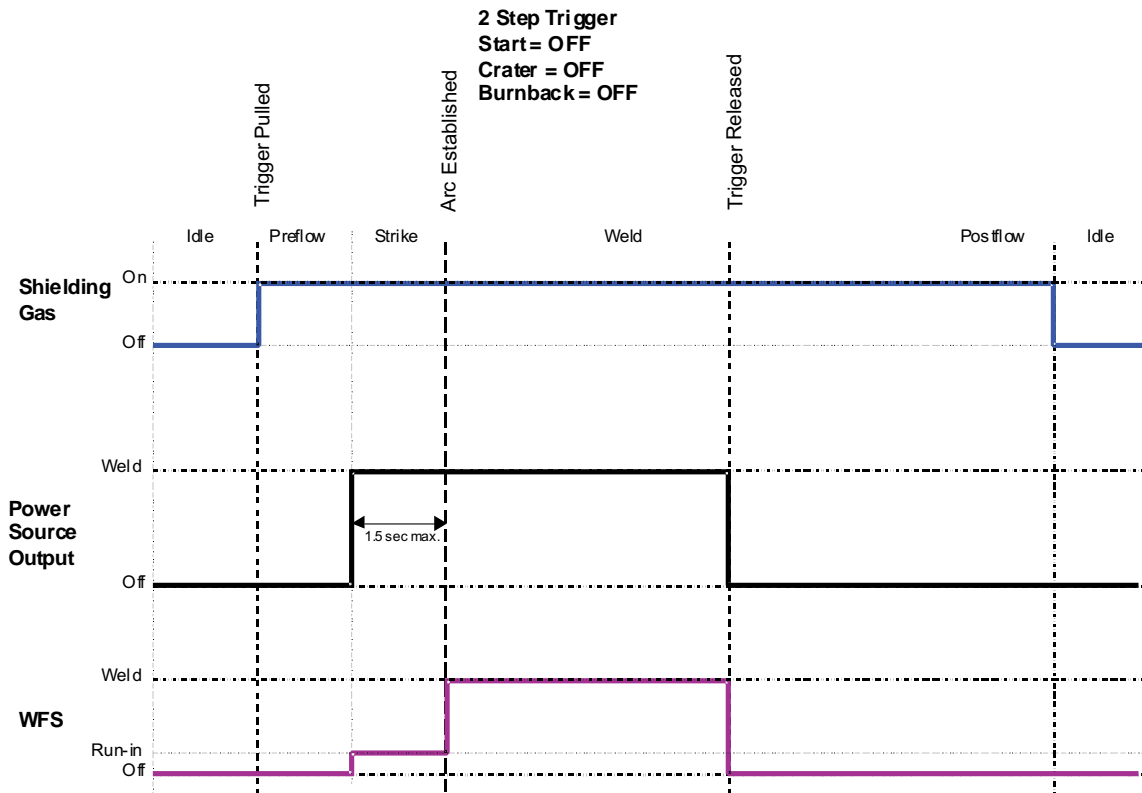

Return to Section TOC

Return to Section TOC

Return to Section TOC

Return to Section TOC

Return to Section TOC

EXAMPLE 2 - 2 STEP TRIGGER: Improved Arc Start and Arc End. Tailoring the arc start and arc end is a common method for reducing spatter and improving weld quality. This can be accomplished with the Start and Burnback functions set to a desired values and Crater set to OFF. (See Figure B.20)

For this sequence,

PREFLOW:

Shielding gas begins to flow immediately when the gun trigger is pulled.

STRIKE:

After preflow time expires, the power source regulates to the start output and wire is advanced towards the work piece at the Strike WFS. If an arc is not established within 1.5 seconds, the power source output and wire feed speed skips to the weld settings.

UPSLOPE:

Once the wire touches the work and an arc is established, both the machine output and the wire feed speed ramp to the weld settings throughout the start time. The time period of ramping from the start settings to the weld settings is called UPSLOPE.

WELD:

After upslope, the power source output and the wire feed speed continue at the weld settings.

BURNBACK:

As soon as the trigger is released, the wire feed speed is turned OFF and the machine output continues for the burnback time.

POSTFLOW:

Next, the machine output is turned OFF and shielding gas continues until the post flow timer expires.

FIGURE B.20

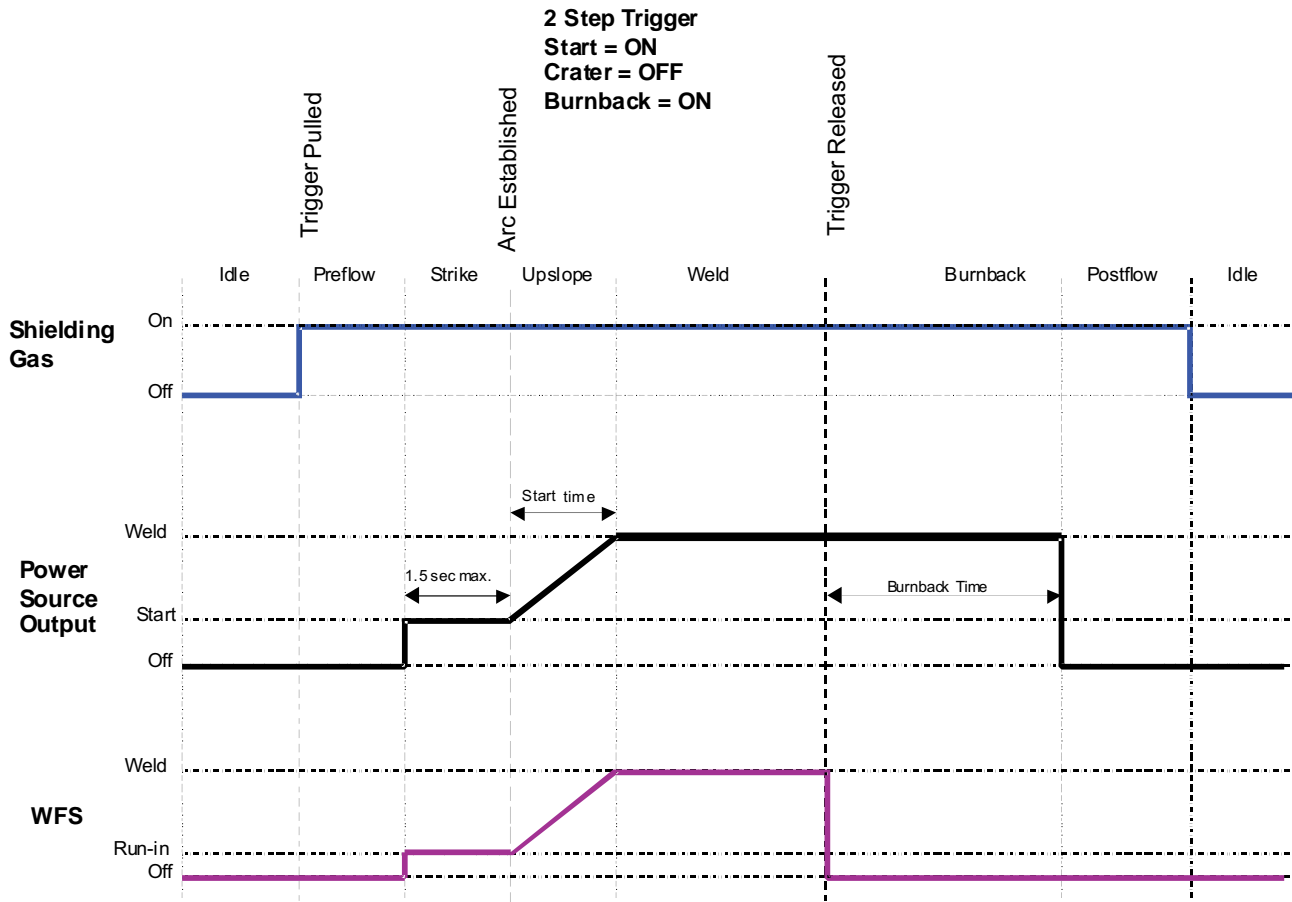

Return to Section TOC

Return to Section TOC

Return to Master TOC

Return to Master TOC

Return to Section TOC

EXAMPLE 3 - 2 STEP TRIGGER: Customized Arc Start, Crater and Arc End. Sometimes it is advantageous to set specific arc start, crater and arc ending parameters for the ideal weld. Many times when welding aluminum crater control is necessary to make a good weld. This is done by setting Start, Crater and Burnback functions to desired values. (See Figure B.21)

For this sequence,

PREFLOW:

Shielding gas begins to flow immediately when the gun trigger is pulled.

STRIKE:

After preflow time expires, the power source regulates to the start output and wire is advanced towards the work piece at the Strike WFS. If an arc is not established within 1.5 seconds, the power source output and wire feed speed skips to the weld settings.

UPSLOPE:

Once the wire touches the work and an arc is established, both the machine output and the wire feed speed ramp to the weld settings throughout the start time. The time period of ramping from the start settings to the weld settings is called UPSLOPE.

WELD:

After upslope, the power source output and the wire feed speed continue at the weld settings.

CRATER:

As soon as the trigger is released, the wire feed speed and power source output ramp to the crater settings throughout the crater time. The time period of ramping from the weld settings to the crater settings is called DOWNSLOPE.

BURNBACK:

After the crater time expires, the wire feed speed is turned OFF and the machine output continues for the burnback time.

POSTFLOW:

Next, the machine output is turned OFF and shielding gas continues until the post flow timer expires.

FIGURE B.21

2 Step Trigger
Start = ON
Crater = ON
Burnback = ON

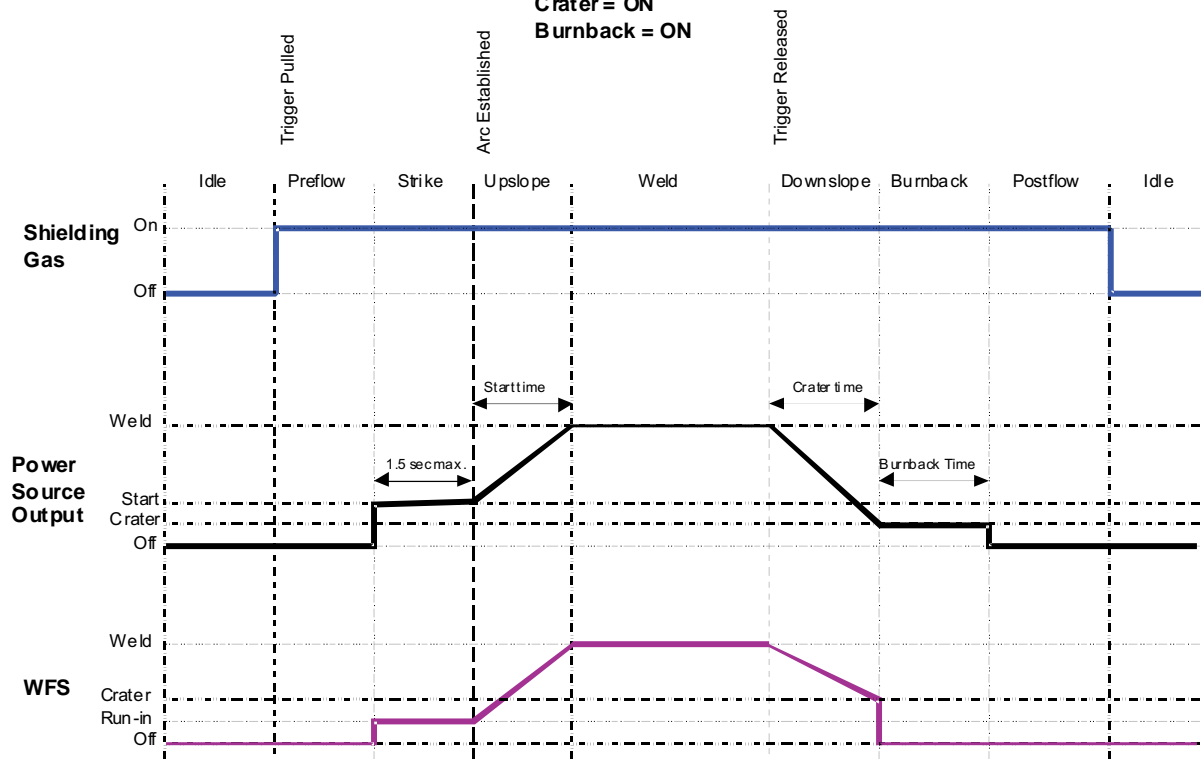

Return to Section TOC
Return to Section TOC
Return to Section TOC
Return to Section TOC
Return to Master TOC
Return to Master TOC
Return to Master TOC
Return to Master TOC

EXAMPLE 4 – 4 STEP TRIGGER: Trigger Interlock

The 4 step trigger can be configured as a trigger interlock. Trigger interlock adds to the welder's comfort when making long welds by allowing the trigger to be released after an initial trigger pull. Welding stops when the trigger is pulled a second time and then released, or if the arc is interrupted. (See Figure B.22)

For this sequence,

PREFLOW:

Shielding gas begins to flow immediately when the gun trigger is pulled.

STRIKE:

After preflow time expires, the power source regulates to the welding output and wire is advanced towards the work piece at the Strike WFS. If an arc is not established within 1.5 seconds, the wire feed speed will jump to the welding wire feed speed.

WELD:

The power source output and the wire feed speed continue at the weld settings. Welding continues when the trigger is pulled a second time.

POSTFLOW:

As soon as the trigger is released for the second time, the power source output and the wire feed speed are turned OFF. Shielding gas flows until the post flow timer expires.

FIGURE B.22

4 Step Trigger
Start = OFF
Crater = OFF
Burnback = OFF

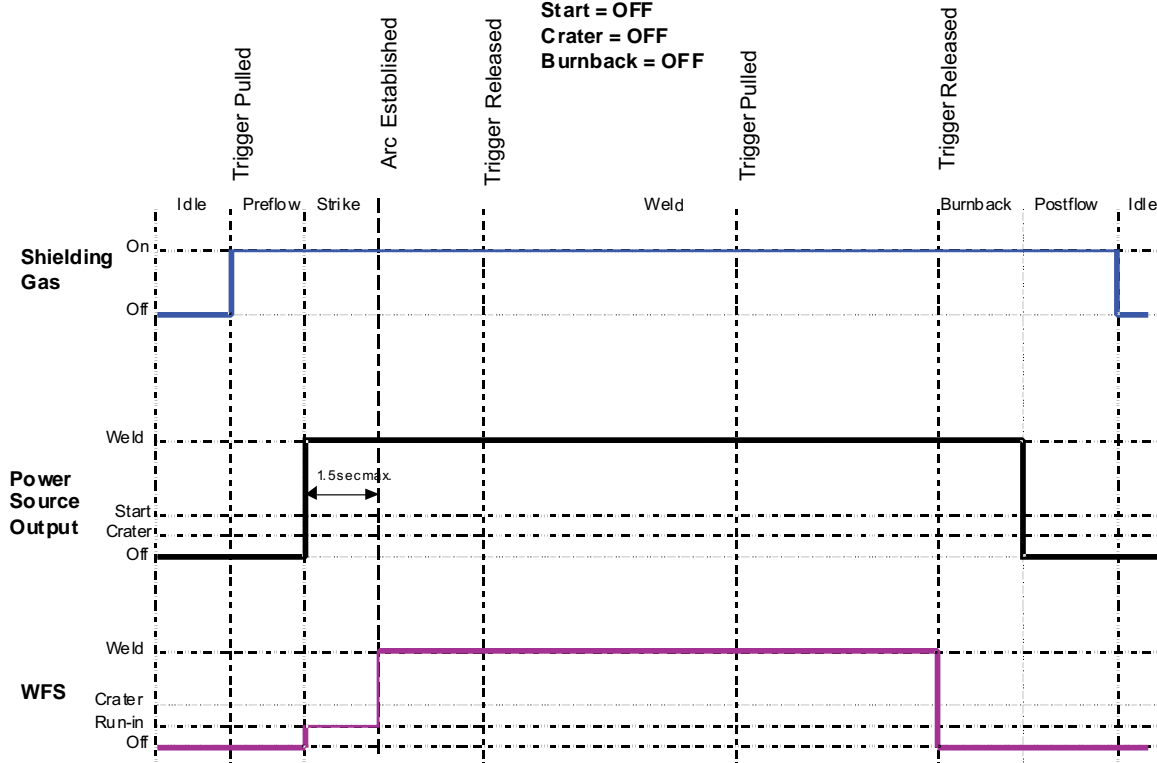

Return to Section TOC
Return to Section TOC
Return to Section TOC
Return to Section TOC
Return to Master TOC
Return to Master TOC
Return to Master TOC
Return to Master TOC

EXAMPLE 5 - 4 STEP TRIGGER: Manual control of Start and Crater times with Burnback ON. The 4 step trigger sequence gives the most flexibility when the Start, Crater and Burnback functions are active. This is a popular choice when welding aluminum because extra heat may be needed during Start and less heat desired during crater. With 4 step trigger, the welder chooses the amount of time to weld at the Start, Weld and Crater settings by using the gun trigger. Burnback reduces the occurrence of wire to sticking into the weld pool at the end of a weld and conditions the end of the wire for the next arc start. (See Figure B.23)

In this sequence,

PREFLOW:

Shielding gas begins to flow immediately when the gun trigger is pulled.

STRIKE:

After preflow time expires, the power source regulates to the start output and wire is advanced towards the work piece at the Strike WFS. If an arc is not established within 1.5 seconds, the power source output and wire feed speed skips to the weld settings.

START:

The power source welds at the start WFS and voltage until the trigger is released.

UPSLOPE:

During upslope, the power source output and the wire feed speed ramp to the weld settings throughout the start time. The time period of ramping from the start settings to the weld settings is called UPSLOPE.

WELD:

After upslope, the power source output and the wire feed speed continue at the weld settings.

DOWNSLOPE:

As soon as the trigger is released, the wire feed speed and power source output ramp to the crater settings throughout the crater time. The time period of ramping from the weld settings to the crater settings is called DOWNSLOPE.

CRATER:

During CRATER, the power source continues to supply output at the crater WFS and voltage.

BURNBACK:

When the trigger is released, the wire feed speed is turned OFF and the machine output continues for the burnback time.

POSTFLOW:

Next, the machine output is turned OFF and shielding gas continues until the post flow timer expires.

FIGURE B.23

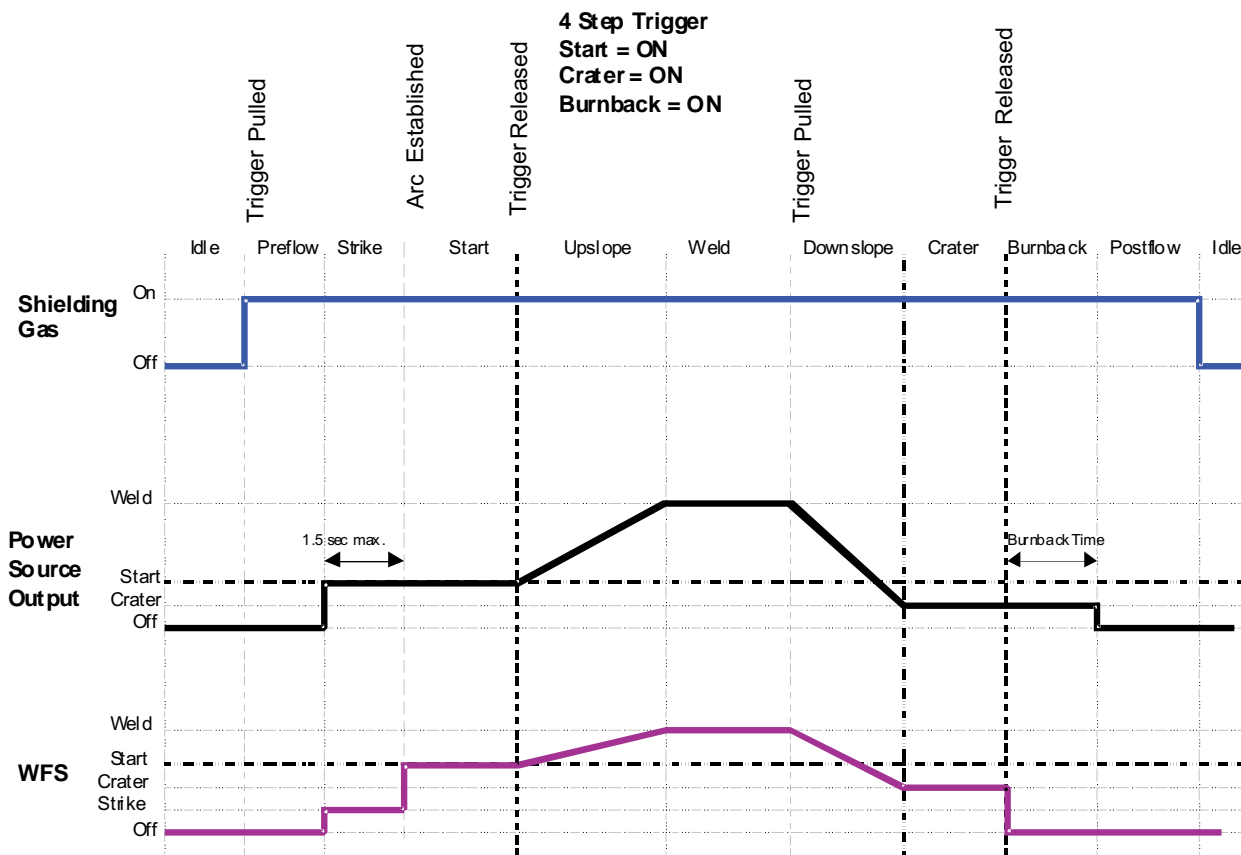

POWER FEED® 25M



Return to Section TOC

Return to Section TOC

Return to Section TOC

Return to Master TOC

Return to Master TOC

Return to Master TOC

REAR CONTROLS:

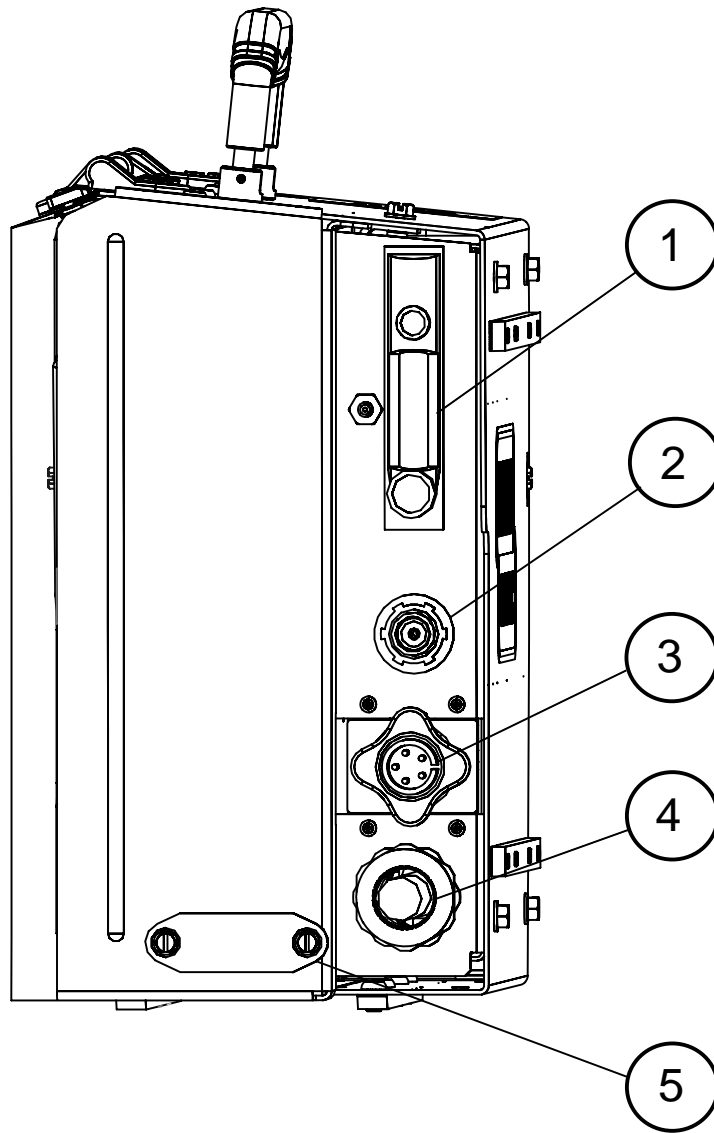

| ITEM | DESCRIPTION |
|------|---|
| 1 | Flow Meter |
| 2 | Shielding Gas Inlet |
| 3 | 5-Pin Arclink Cable Connector |
| 4 | Electrode Cable |
| 5 | Cover for Optional Water Line Connector |

Return to Section TOC

Return to Section TOC

Return to Section TOC

Return to Section TOC

Return to Master TOC

Return to Master TOC

Return to Master TOC

Return to Master TOC

FLOW METER

The flowmeter shows the flow rate of shielding gas and has a valve to adjust the flow. The flow meter is scaled for CO₂, Ar, and CO₂/Ar blends. It is not calibrated and is for reference purposes only. The middle of the ball indicates the flow rate of shielding gas.

Adjust the flow rate while depressing the gas purge switch by turning the valve at the bottom of the meter. Most weld procedures require 25-40 scfh (11.8 - 18.9 lpm) for sufficient shielding gas coverage. Gun angle, nozzle diameter, joint configuration and wind conditions may effect the amount of shielding gas required.

| SCFH | Liter/Min. |
|------|------------|
| 10 | 4.7 |
| 20 | 9.4 |
| 30 | 14.2 |
| 40 | 18.9 |
| 50 | 23.6 |
| 60 | 28.3 |
| 70 | 33.1 |
| 80 | 37.8 |

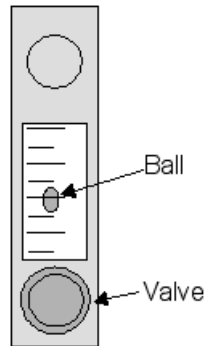

OPERATION ON LINCNET™ POWER SOURCES

The POWER FEED® 25M is an ArcLink® wire feeder and is designed for operating on ArcLink® Power Wave® power sources. It is also capable of operating on older LincNet™ Power Wave® power sources though not all of the features will be active.

When operating with a LincNet™ power source,

- Limits and Lock-outs are not available.
- The weld mode description is not displayed when choosing weld modes.
- When the weld mode is changed, any Arc Control values will remain as set for the previous weld mode.
- Push-Pull guns will not function.
- The IR port will not operate.
- Error codes will be displayed as "ERR100". Error codes are deciphered by the flashing of the Status LED. (Counts of red flashes)
- In the Set-Up menu, only parameters P.0 to P.99 are available.

POWER FEED® 25M



AccessoriesC-1

 Factory Installed EquipmentC-2

 Drive Roll Kits usedC-2

 Common Packages with Accesories UsedC-3/C-6

 Installation of Water Cooling KitC-6

 Python water cooled GunsC-7

Return to Master TOC

Return to Master TOC

Return to Master TOC

Return to Master TOC





FACTORY INSTALLED EQUIPMENT

- K1500-2 Gun Receiver Bushing.

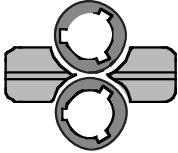
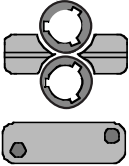
DRIVE ROLL KITS USED







- Drive Roll Kits (Includes drive rolls and inner wire guide necessary to feed the identified wire size and type).







| WIRE TYPE | ELECTRODE SIZE | KP KIT | | |
|-----------------|--|---|---|---|
| Steel Wires: | .023-.030 (0.6-0.8mm) .035 (0.9mm) .045 (1.2mm) .052 (1.4mm) 1/16 (1.6mm) .035,.045 (0.9, 1.2mm) .040 (1.0mm) | KP1696-030S KP1696-035S KP1696-045S KP1696-052S KP1696-1/16S KP1696-1 KP1696-2 | Includes: 2 V groove drive rolls and inner wire guide. |  |
| Cored Wires: | .030-.035" (0.8-0.9mm) .040-.045" (1.0-1.2mm) .052" (1.4mm) 1/16" (1.6mm) .068-.072" (1.7-1.8mm) 5/64" (2.0mm) 3/32" (2.4mm) | KP1697-035C KP1697-045C KP1697-052C KP1697-1/16C KP1697-068 KP1697-5/64 KP1697-3/32 | Includes: 2 Knurled drive rolls and inner wire guide. | |
| Aluminum Wires: | .035" (0.9 mm) .040" (1.0mm) 3/64" (1.2mm) 1/16" (1.6mm) | KP1695-035A KP1695-040A KP1695-3/64A KP1695-1/16A | Includes: 2 polished U groove drive rolls, outer wire guide and inner wire guide. |  |

| | | | |
|----------|-------------------------------------|---|---|
| K2429-1 | ArcLink "T" Cable Adapter | Includes: 1 "T" adapter for connecting two wire feeders to one power source. |  |
| K857 | Remote Output Control | Includes: 1 remote output control pendant with a 25' cable. Used most often with SMAW welding. |  |
| K857-1 | Remote Output Control | Includes: 1 remote output control pendant with a 100' cable. Used most often with SMAW welding. |  |
| K2596-1 | Aluminum Case | Includes: a complete aluminum case. Decals, skids, insulation and latches are all preassembled. | |
| K2596-2 | Plastic Case | Includes: a complete engineered plastic case. Decals and latches are all preassembled. | |
| K2593-xx | #1 Co-Axial Power Cable | Includes: AWG #1 Coaxial weld cable of length "xx". Ends of the weld cable have lug connections. Use for Pulse or STT™ welding. | |
| K1796-xx | Co-Axial Power Cable | Includes: 1/0 Coaxial weld cable of length "xx". Ends of the weld cable have lug connections. Use for Pulse or STT™ welding. |  |
| K1803-1 | Work and Feeder Cables Package | Includes: 1/0 Coaxial weld cable of length "xx". Ends of the weld cable have lug connections. Use for Pulse or STT™ welding. |  |
| K1840-xx | Weld Power Cable, Twist-Mate to Lug | Includes: Twist-Mate to Lug 2/0 cable 14' (1.2m) long with Ground Clamp, and Twist-Mate to Lug 2/0 Cable 9' (2.7m) long. | |
| K1842-xx | Weld Power Cable, Lug to Lug | Includes: Twist-Mate to Lug, 1/0 cable of length "xx". | |

POWER FEED® 25M



| | | | |
|----------------------------------|---|--|---|
| K1543-xx | Digital Control Cable | Includes: 5 pin to 5 pin wire feeder to power source control cable. Cables may be connected end-to-end to make a longer cable. |  |
| K910-1 | Ground Clamp | Includes: One 300 Amp Ground Clamp. |  |
| K910-2 | Ground Clamp | Includes: One 500 Amp Ground Clamp. |  |
| K1500-1 | Gun Receiver Bushing (for guns with K466-1 Lincoln gun connectors; Innershield and Subarc guns) | Includes: Gun receiver bushing, set screw and hex key wrench. |  |
| K1500-2 (Included with PF25M) | Gun Receiver Bushing (for guns with K466-2, K466-10 Lincoln gun connectors; Magnum 200/300/400 guns and compatible with Tweco® #2-#4) | Includes: Gun receiver bushing with hose nipple, set screw and hex key wrench. |  |
| K1500-3 | Gun Receiver Bushing (for guns with K613-7 Lincoln gun connectors; Magnum 550 guns and compatible with Tweco® #5) | Includes: Gun receiver bushing with hose nipple, set screw and hex key wrench. |  |
| K1500-4 | Gun Receiver Bushing (for gun with K466-3 Lincoln gun connectors; compatible with Miller® guns.) | Includes: Gun receiver bushing with hose nipple, set screw and hex key wrench. |  |

| | | | |
|---------|---|--|---|
| K1500-5 | Gun Receiver Bushing (compatible with Oxo® guns.) | Includes: Gun receiver bushing with hose nipple, 4 guide tubes, set screw and hex key wrench. |  |
| K489-7 | Gun Receiver Bushing (for Lincoln Fast-Mate guns.) | Includes: Gun receiver bushing with trigger connector. |  |
| K2339-1 | Push-Pull Gun Connection Kit | Used with K2211-xx and K2212-xx Python Guns. Includes: Push-Pull gun bushing, fittings, valve removal tool, modified gas bypass valve and control cable extension. |  |
| K590-6 | Water Connection Kit | Includes: 2 hoses with female quick connectors at each end, 2 male connectors for 3/16" ID hose, 2 male connectors for 1/4" ID hose, and mounting hardware. | |
| K435 | Spindle Adapter, for mounting 14 lb. (6.4 kg) Innershield Coils on 2 in (51 mm) spindles. | Includes: Spindle Adapter made from 2 coil retainers. (Electrode not included.) |  |
| K468 | Spindle Adapter, for mounting 8in (203mm) diameter spools on 2 in (51 mm) spindles. | Includes: 2 Spindle Adapters, one for 2" wide spools and the other for 3" wide spools. | |
| K659-1 | Gas Guard Regulator | Includes: Gas Guard Regulator and adjustment key. |  |
| 3000290 | Adjustable Gas Regulator | Includes: Gas Regulator for Mixed Gases and 10' (3.0m) Hose. |  |
| K586-1 | Deluxe Adjustable Gas Regulator | Includes: Deluxe Gas Regulator for Mixed Gases, Adapter for CO2 and 10' (3.0m) Hose. |  |

POWER FEED® 25M



INSTALLATION OF THE K590-6 WATER COOLING KIT

⚠ WARNING



ELECTRIC SHOCK can kill.

- Turn the input power OFF at the disconnect switch before working on this equipment.
- Do not touch electrically hot parts.
- Only qualified personnel should install, use or service this equipment.

The K590-6 components are rated up to 70 psi (5 bar) and 158°F (70°C). Use a coolant fluid that is compatible with the water cooler and the gun.

Tools required:

- 3/8" wrench
- 5/16" nut driver
- medium flat bladed screw driver
- cutting tool

1. Turn power off at the welding power source.
2. Remove the screws securing the case to the inner module using a 3/8" wrench.

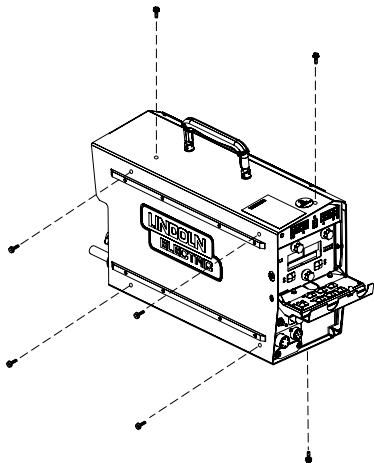

3. Remove the module from the case by lifting the front of the module approximately .25" (6 mm) and then sliding forward.

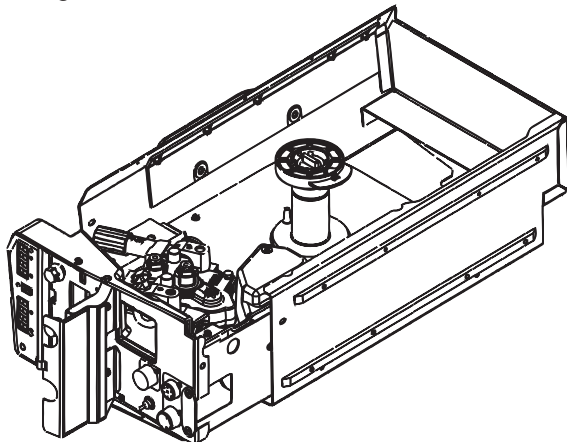

4. Use a 5/16" nut driver to remove the screws holding the water cooling cover on the case front of the inner module and on the rear of the case.

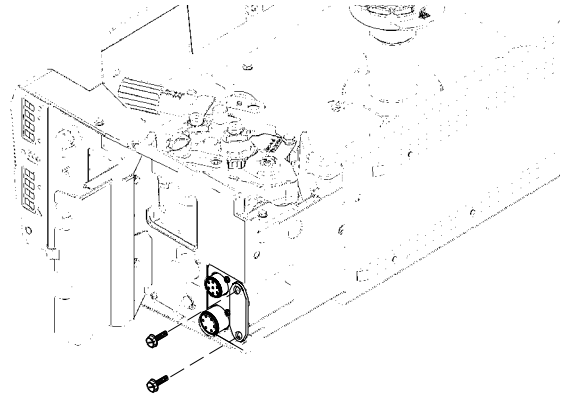

5. Install the fitting and hose assembly to the case front. Route the hoses along the bottom of the inner module and out through the cutout of the cover. Slide the module back into the case.

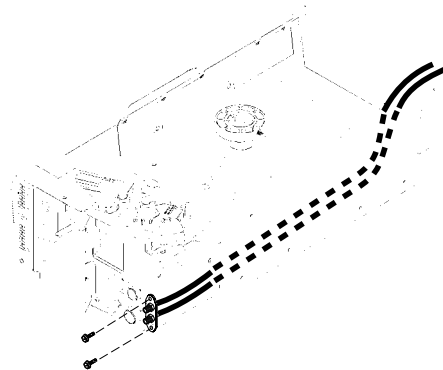

6. Secure the module to the case with the screws. (Shown in Step 2)
7. Install the fitting assembly to the rear of the case

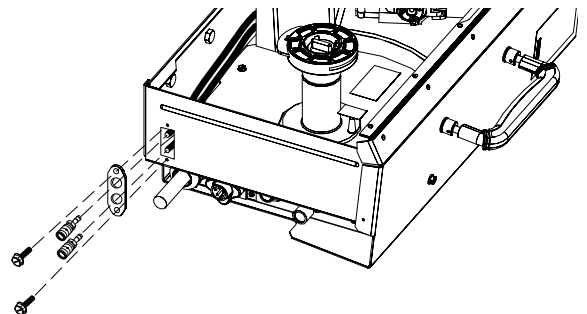

8. Slide the hose clamps on to the hoses. Trim the hoses to length so that they lay flat on the case bottom. Slide the hoses on to the fittings on the case rear and secure with the hose clamps.

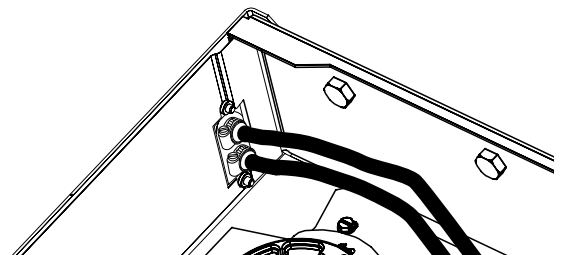

POWER FEED® 25M

LINCOLN
ELECTRIC

⚠ WARNING

ELECTRIC SHOCK can kill.

- Turn the input power OFF at the disconnect switch before working on this equipment.
- Do not touch electrically hot parts.
- Only qualified personnel should install, use or service this equipment.

Water cooled guns require the installation of the K590-6 Water Connection Kit. The kit components are rated up to 70 psi (5bar) and 158°F (70°C). See this Section for kit installation instructions.

PYTHON WATER COOLED GUNS

(See Figure C.1)

K2212-xx push-pull guns require both the K590-6 water connection kit and the K2339-1 push-pull gun connection kit. The hoses from the water connection kit assemble directly to the push-pull gun bushing as shown below. Secure the conduit from the python gun in the gun bushing by using the thumb screw.

FIGURE C.1

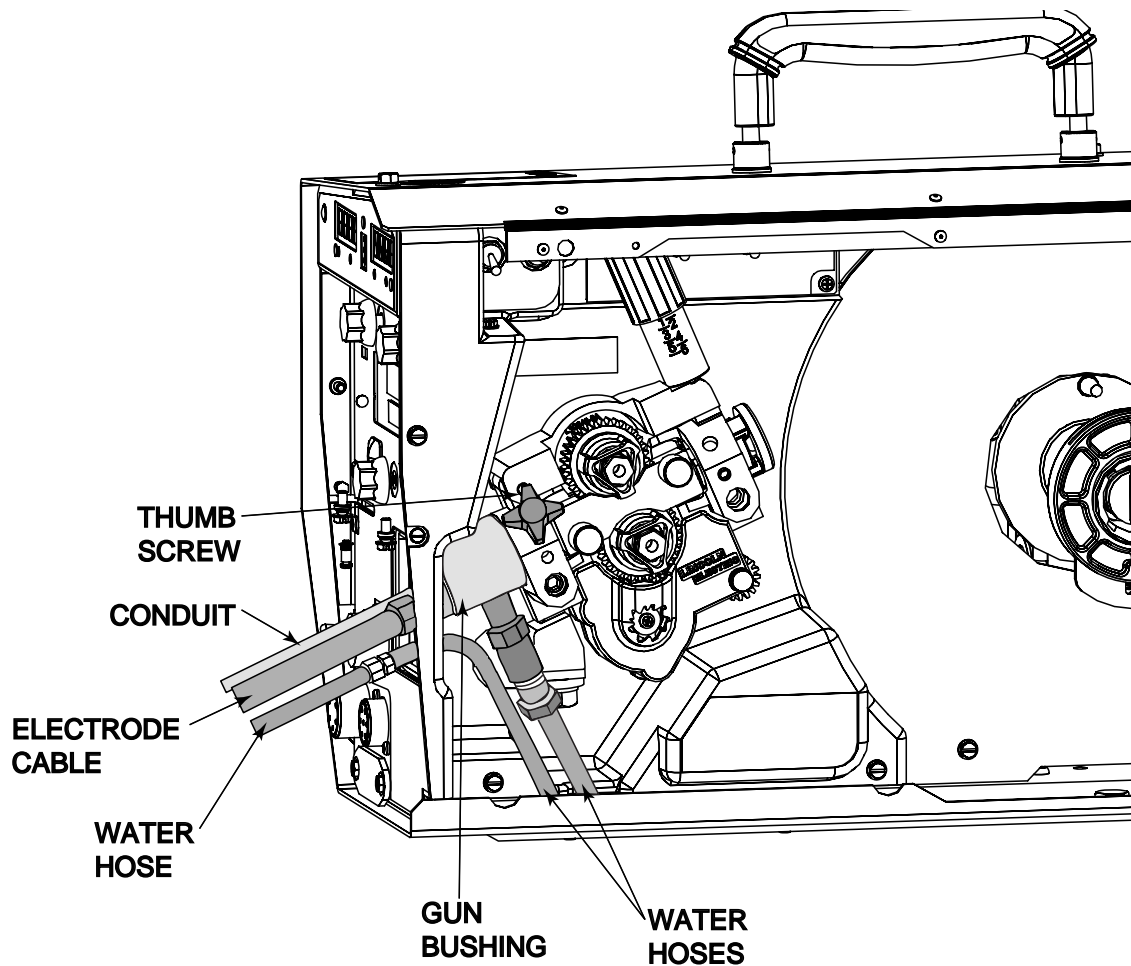

POWER FEED® 25M

LINCOLN
ELECTRIC

Return to Section TOC
Return to Master TOC
Return to Section TOC
Return to Master TOC
Return to Section TOC
Return to Master TOC
Return to Section TOC
Return to Master TOC

POWER FEED® 25M



MaintenanceD-1

Safety PrecautionsD-2

Routine MaintenanceD-2

Periodic MaintenanceD-2

Calibration SpecificationD-2

Return to Master TOC

Return to Master TOC

Return to Master TOC

Return to Master TOC

MAINTENANCE

SAFETY PRECAUTIONS

⚠ WARNING

ELECTRIC SHOCK can kill.



- Do not operate with covers removed.
- Turn off power source before installing or servicing.
- Do not touch electrically hot parts.

- Turn the input power to the welding power source off at the fuse box before working in the terminal strip.
- Only qualified personnel should install, use or service this equipment.

ROUTINE MAINTENANCE

- Check weld cables, control cables and gas hoses for cuts.
- Clean and tighten all weld terminals.

PERIODIC MAINTENANCE

- Clean drive rolls and inner wire guide and replace if worn.
- Blow out or vacuum the inside of the feeder.

CALIBRATION SPECIFICATION

All calibrations are factory set on the POWER FEED® 25M.

To verify the wire feed speed:

- Assemble a .045 (1.2mm) drive roll kit into the POWER FEED® 25M.
- Load a spool of .045 (1.2mm) electrode and thread the electrode through the wire drive.
- Adjust the wire feed speed to 300 in/min (7.62m/min).
- Press the COLD FEED switch and measure the actual wire feed speed with a calibrated wire feed speed tachometer.
- The measured wire feed speed should be within 2% of the set value.
- If no feed speed meter is available, cut the wire at gun tip. Cold inch for 5 seconds at 300 inches/minute. Measure the wire - should be 24 inches +1, -2 inches.

To verify the voltage display:

- Set the welding power source and POWER FEED® 25M to a CV procedure that gives steady "spray" transfer in the arc.
- While a weld is being made, measure the voltage from the feed plate to work with a calibrated volt meter.
- The displayed voltage on the POWER FEED® 25M should be within 2% of the measured value.

POWER FEED® 25M



Theory of OperationE-1

General Physical DescriptionE-2

General Functional DescriptionE-2

POWER FEED® 25ME-3

Control BoxE-4

Component Status LightsE-5

FIGURE E.1 BLOCK LOGIC DIAGRAM

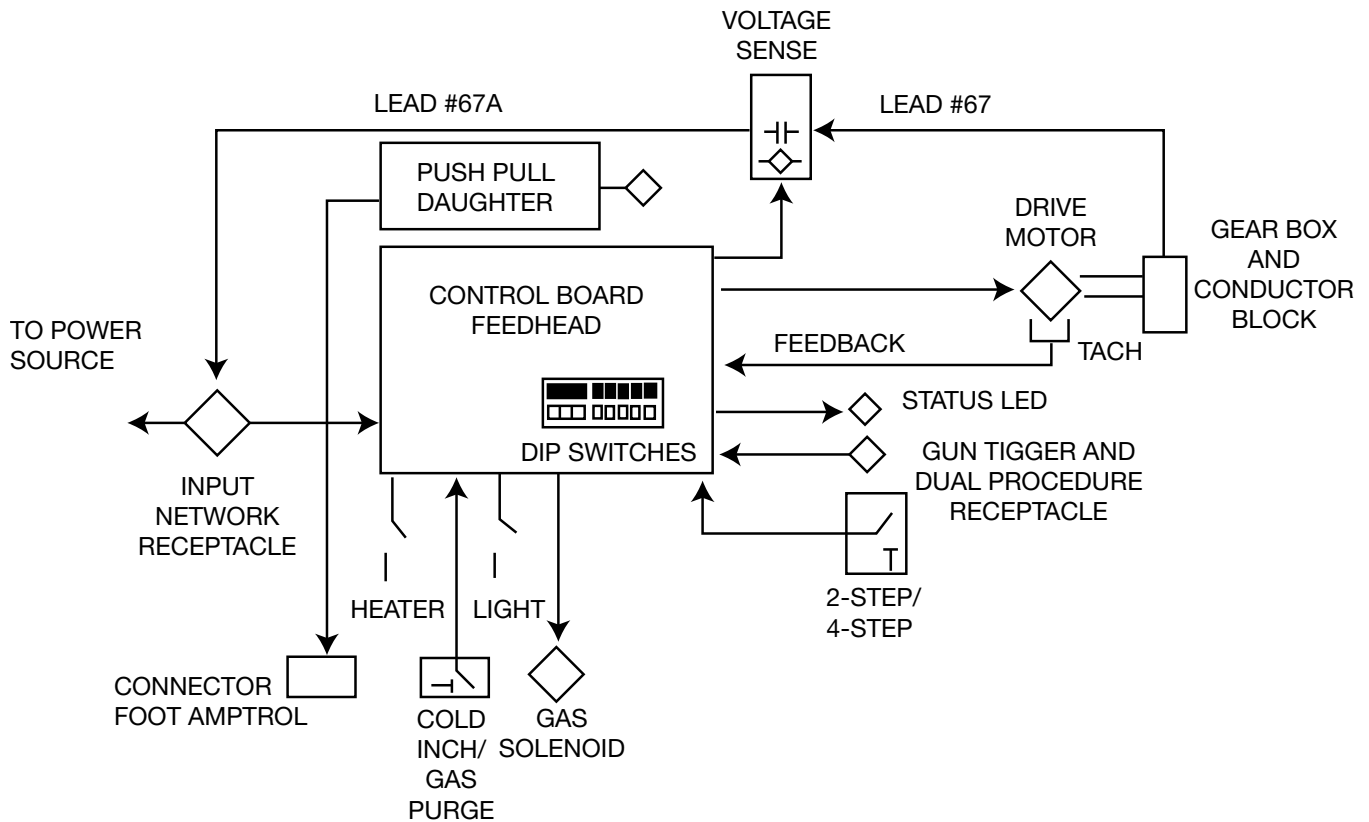

POWER FEED® 25M



FIGURE E.2 - GENERAL PHYSICAL DESCRIPTION

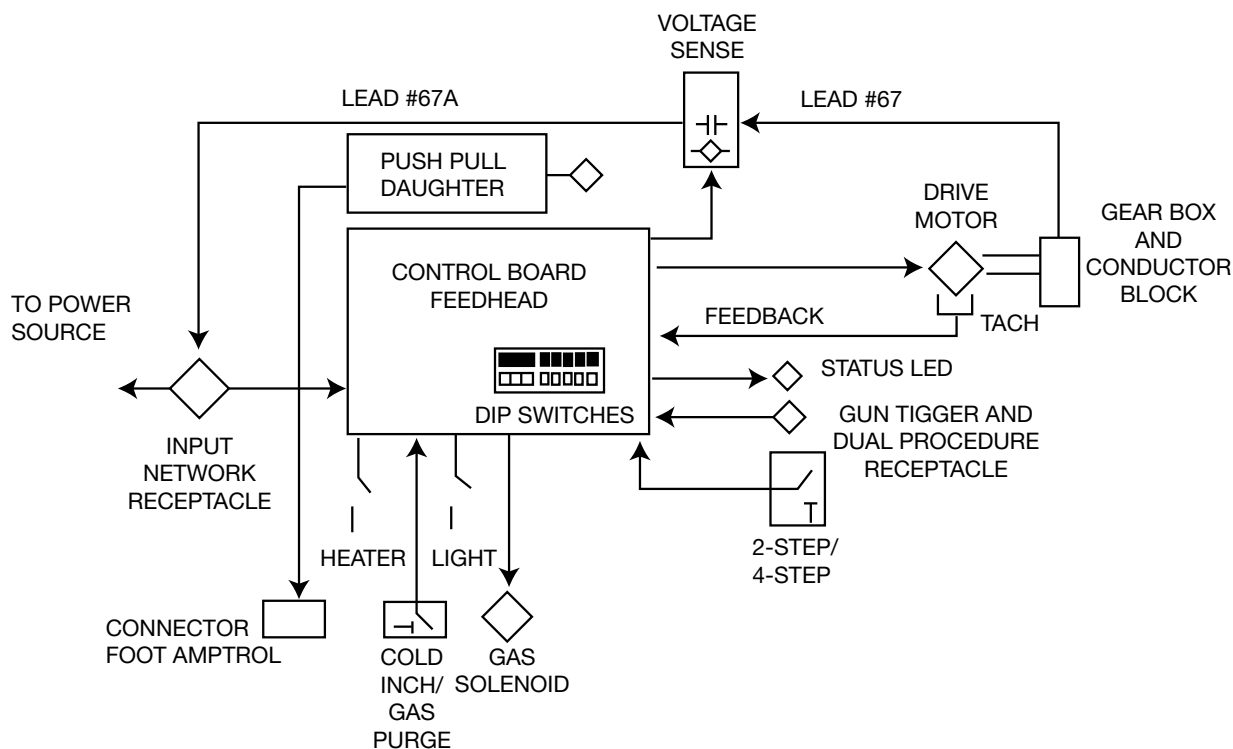

GENERAL DESCRIPTION

The POWER FEED® 25 Single Wire Feeder is a wire feeder, consisting of two components - a **wire drive** and a **control box** - are available assembled as a **bench unit** or as a **boom system**. High speed, highly reliable digital cables connect the components together and to the Power Wave power source.

The POWER FEED® 25M Wire Feeder system has the ability to connect to one power source, use the same power source.

The powerful two roll wire drive system sets the industry standard for ease of use. Its patented design allows for tool-less change out of wire guides and drive rolls greatly reducing set up time.

GENERAL FUNCTIONAL DESCRIPTION

- The POWER FEED® 25M Wire Feeder is a highly versatile wire feeder with easy to use features that make it easy for the operator to adjust the arc for specific preferences.
- The new MSP4 panel clearly displays key welding information. Use the MSP4 panel to quickly adjust weld settings, arc starting parameters, arc end parameters and set-up variables.
- The POWER FEED® 25M Wire Feeder is provided with an infrared red (IR) port. Transferring welding settings is accomplished with a common palm computer.
- When the POWER FEED® 25M Wire Feeder is coupled to a Power Wave welding power source, the result is a welding system with absolutely superior arc performance.

NOTE: Unshaded areas of Block Logic Diagram are the subject of discussion

POWER FEED® 25M



FIGURE E.3 - GAS SOLENOID CONTROLS

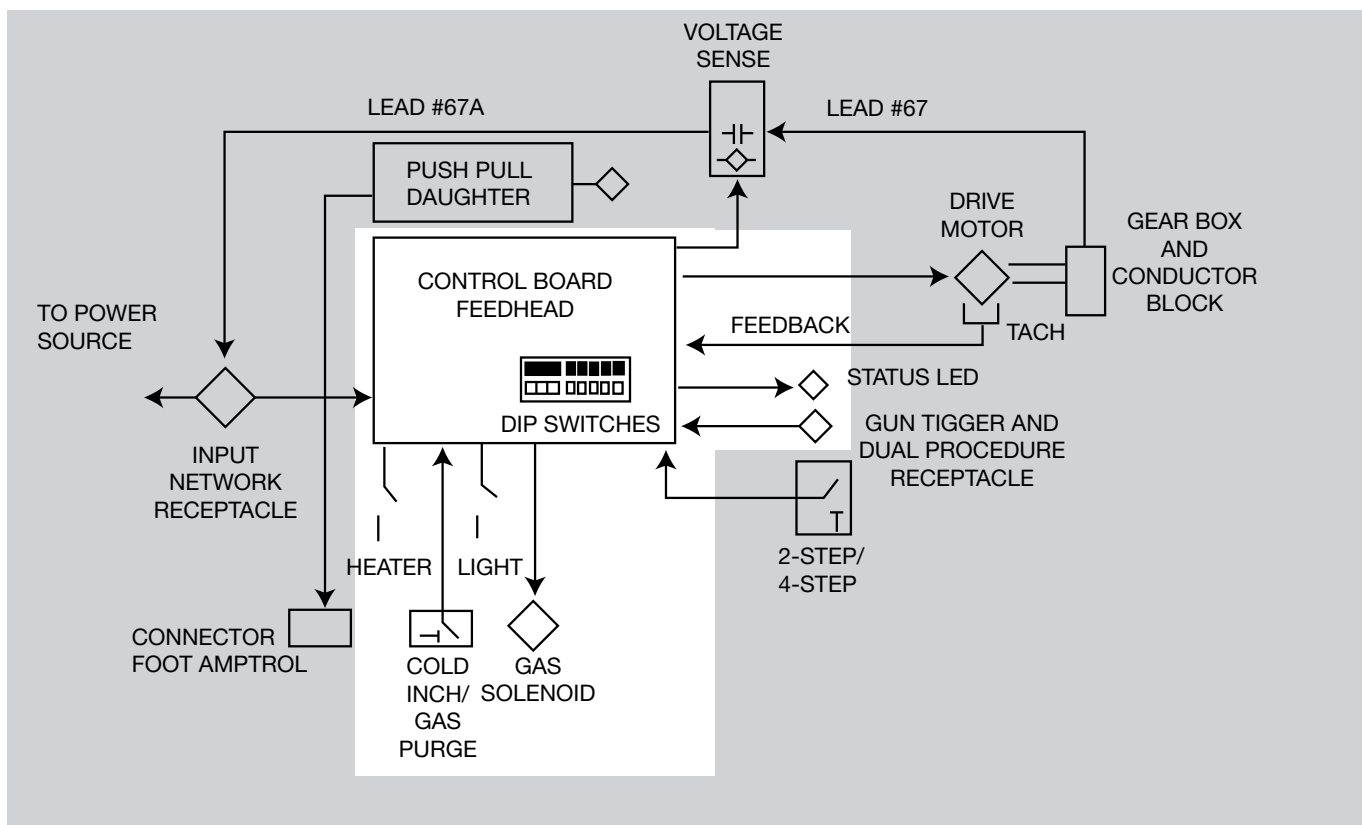

POWER FEED® 25M

The POWER FEED® 25M is a two roll, high performance, digitally controlled, modular wire feeder that operates on 40 VDC input power. It is designed to be a part of a modular, multi-process welding system. Refer to Figure E.2.

Network communications, intelligence, PC board input power, and arc voltage feedback is received and transmitted through the input network receptacle.

The feed head drive control board processes the information it receives from the various user operated switches such as the gun trigger, 2-step/4-step, and cold inch switches and sends this information to other system components. This information is evaluated and the correct commands are transmitted to the feed head drive. The feed head drive control board then sends the signals to energize the active components such as the solenoid and wire drive motor. The tach feedback signal is processed on the feedhead board which regulates the motor armature voltage so as to maintain the required wire feed speed.

When the gun trigger is pulled, the voltage sense board relays the electrode sense signal to the input network receptacle for processing by the power source.

The STATUS LED is designed to blink a red and green code if a fault should occur.

There is one DIP switch bank located on the wire feedhead drive board. It is labeled S1 and is used to set gear ratios and arc polarity.

GAS SOLENOID

The gas solenoid permits the POWER FEED® 25M to be used for gas metal arc welding (GMAW) processes. When the gun trigger circuit is activated, the control board signals the solenoid to activate, which allows sheilding gas to flow through the gun to the arc.

NOTE: Unshaded areas of Block Logic Diagram are the subject of discussion

POWER FEED® 25M



FIGURE E.4 - CONTROL BOX

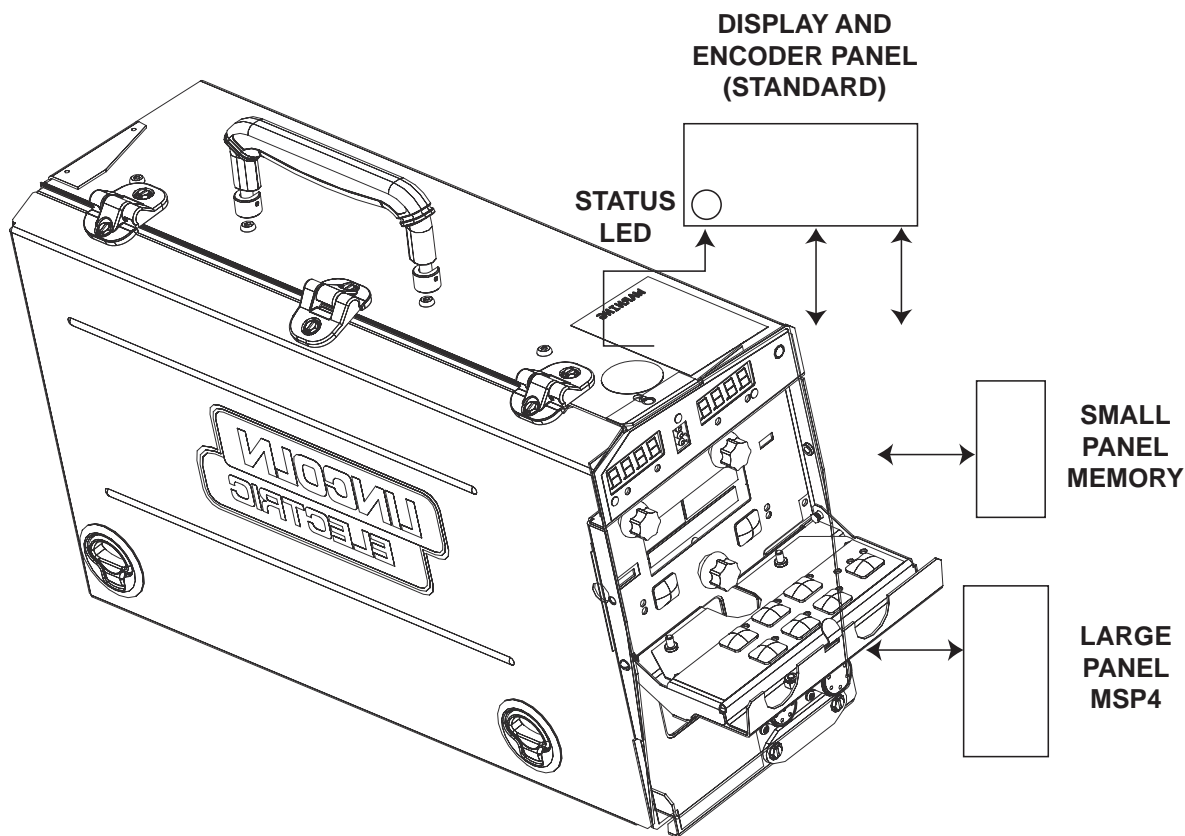

CONTROL BOX (USER INTERFACE)

The POWER FEED® 25M wire feeders do not have User Interface Boards in the control box. On these models the User Interface Bd circuitry is on the feed head Bd located in the wire drive box.

COMPONENT STATUS LIGHTS

Each network component has a single status light. The light is a bicolor, Green/Red, LED. The purpose of the status light is to allow the operator to quickly identify that the system is working properly or, if not, which

component is causing the problem. By using the status lights the operator can quickly pinpoint the system problem to a particular component. See the following table for a complete listing and description of all status light conditions.

NOTE: The green light **ON and steady** indicates a normal functioning system.

STATUS LIGHT STATES

| LED State | Power Source LED | LED on any other nodes (components); Wire Feeder, Control Box Etc. |
|---|---|---|
| Off | Power Source is not turned ON or is not functioning correctly. | The system component is not receiving input power or is faulty. |
| Green LED blinking at a "normal" rate | It should only blink for a few seconds while the system is mapping (identifying components). If blinking continues every group may have a mapping error. (DIP switches may be set incorrectly). | It should only blink for a few seconds until the system component (node) has been recognized. If the blinking continues at least one node in the group has a mapping error (DIP switches may be set incorrectly). The node or nodes with mapping errors will be blinking red. <ul style="list-style-type: none"> • There may be too many components in the group. All components in the group will be blinking green. • The power source bus may not be available. The bus may be being used to program another component. • The LED's of the power source and the component being programmed will be solid green. |
| Red LED blinking at a "normal" rate | Indicates a recoverable communication fault. The power source should automatically recover: If it cannot recover the LED will be solid red. | Indicates a recoverable communication fault most likely caused by one of the following. <ul style="list-style-type: none"> • More than one control box (UI) in the group. All control boxes in the group will be blinking red. • No control box (UI) in the group. All nodes in the group will be blinking red. • More than one node, of the same equipment type, has the same group and feed head (FH) numbers. All these nodes will be blinking red. • The feed head DIP switches may be set to zero. The nodes with DIP switches set to zero will be blinking red. • The node bus may be off. |
| Red/Green LED blinking at a "normal" rate | Indicates a recoverable hardware fault such as over temperature, overload shutdown etc. | Indicates a recoverable hardware fault such as over temperature, overload shutdown etc. Could also be an open shutdown circuit at the feed head (leads 570, 572 with tab terminals) typically used for water flow shutdown switches. |

STATUS LIGHT STATES (CON'T)

| LED State | Power Source LED | LED on any other nodes (components); Wire Feeder, Control Box Etc. |
|---------------------------------|--|---|
| Red LED blinking at a fast rate | Power source needs to be reprogrammed. Contact your Local Authorized Lincoln Field Service Facility. | System component (node) needs to be reprogrammed. Contact your Local Authorized Lincoln Field Service Facility. |
| Red LED ON and steady | Power source has a non-recoverable hardware fault. Contact your Local Authorized Lincoln Field Service Facility. | System component (node) has a non-recoverable hardware fault. Contact your Local Authorized Lincoln Field Service Facility. |
| Green LED ON and steady | System normal and functional. | System normal and functional. |

Normal Blinking LED - Each illumination should exist for 0.5 seconds.

Fast Blinking LED - Each illumination should exist for 0.1 seconds.

Troubleshooting and RepairF-1

 How to Use Troubleshooting Guide F-2

 PC Board Troubleshooting Procedures F-3

 Troubleshooting GuideF-4 / F-12

 Test ProceduresF-13 / F-21

 Voltage Sense PC Board Test F-13

 Tach Feedback Test F-15

 Drive Motor Test F-17

 Gear Box and Drive Motor Removal and Replacement F-19

 Retest and Repair F-22

Return to Master TOC

Return to Master TOC

Return to Master TOC

Return to Master TOC

HOW TO USE TROUBLESHOOTING GUIDE

⚠ WARNING

Service and Repair should only be performed by Lincoln Electric Factory Trained Personnel. Unauthorized repairs performed on this equipment may result in danger to the technician and machine operator and will invalidate your factory warranty. For your safety and to avoid Electrical Shock, please observe all safety notes and precautions detailed throughout this manual.

This Troubleshooting Guide is provided to help you locate and repair possible machine malfunctions. Simply follow the three-step procedure listed below.

Step 1. LOCATE PROBLEM (SYMPTOM).

Look under the column labeled "PROBLEM (SYMPTOMS)". This column describes possible symptoms that the machine may exhibit. Find the listing that best describes the symptom that the machine is exhibiting. Symptoms are grouped into the following categories: output problems, function problems, wire feeding problems, and welding problems.

Step 2. PERFORM EXTERNAL TESTS.

The second column labeled "POSSIBLE AREAS OF MISADJUSTMENT(S)" lists the obvious external possibilities that may contribute to the machine symptom. Perform these tests/checks in the order listed. In general, these tests can be conducted without removing the case wrap-around cover.

Step 3. RECOMMENDED COURSE OF ACTION

The last column labeled "Recommended Course of Action" lists the most likely components that may have failed in your machine. It also specifies the appropriate test procedure to verify that the subject component is either good or bad. If there are a number of possible components, check the components in the order listed to eliminate one possibility at a time until you locate the cause of your problem.

All of the referenced test procedures referred to in the Troubleshooting Guide are described in detail at the end of this chapter. Refer to the Troubleshooting and Repair Table of Contents to locate each specific Test Procedure. All of the specified test points, components, terminal strips, etc. can be found on the referenced electrical wiring diagrams and schematics. Refer to the Electrical Diagrams Section Table of Contents to locate the appropriate diagram.

⚠ CAUTION

If for any reason you do not understand the test procedures or are unable to perform the tests/repairs safely, contact the Lincoln Electric Service Department for technical troubleshooting assistance before you proceed. Call 1-888-935-3877.

PC BOARD TROUBLESHOOTING PROCEDURES

⚠ WARNING**ELECTRIC SHOCK
can kill.**

- Have an electrician install and service this equipment. Turn the input power OFF at the fuse box before working on equipment. Do not touch electrically hot parts.

⚠ CAUTION

Sometimes machine failures appear to be due to PC board failures. These problems can sometimes be traced to poor electrical connections. To avoid problems when troubleshooting and replacing PC boards, please use the following procedure:

1. Determine to the best of your technical ability that the PC board is the most likely component causing the failure symptom.
2. Check for loose connections at the PC board to assure that the PC board is properly connected.
3. If the problem persists, replace the suspect PC board using standard practices to avoid static electrical damage and electrical shock. Read the warning inside the static resistant bag and perform the following procedures:

PC board can be damaged by static electricity.

- Remove your body's static charge before opening the static-shielding bag. Wear an anti-static wrist strap. For safety, use a 1 Meg ohm resistive cord connected to a grounded part of the equipment frame.

- If you don't have a wrist strap, touch an un-painted, grounded, part of the equipment frame. Keep touching the frame to prevent static build-up. Be sure not to touch any electrically live parts at the same time.

- Tools which come in contact with the PC board must be either conductive, anti-static or static-dissipative.

- Remove the PC board from the static-shielding bag and place it directly into the equipment. Don't set the PC board on or near paper, plastic or cloth which could have a static charge. If the PC board can't be installed immediately, put it back in the static-shielding bag.

- If the PC board uses protective shorting jumpers, don't remove them until installation is complete.

- If you return a PC board to The Lincoln Electric Company for credit, it must be in the static-shielding bag. This will prevent further damage and allow proper failure analysis.

4. Test the machine to determine if the failure symptom has been corrected by the replacement PC board.

NOTE: It is desirable to have a spare (known good) PC board available for PC board troubleshooting.

NOTE: Allow the machine to heat up so that all electrical components can reach their operating temperature.

5. Remove the replacement PC board and substitute it with the original PC board to recreate the original problem.
 - a. If the original problem does not reappear by substituting the original board, then the PC board was not the problem. Continue to look for bad connections in the control wiring harness, junction blocks, and terminal strips.
 - b. If the original problem is recreated by the substitution of the original board, then the PC board was the problem. Reinstall the replacement PC board and test the machine.
6. Always indicate that this procedure was followed when warranty reports are to be submitted.

NOTE: Following this procedure and writing on the warranty report, "INSTALLED AND SWITCHED PC BOARDS TO VERIFY PROBLEM," will help avoid denial of legitimate PC board warranty claims.

Observe Safety Guidelines detailed in the beginning of this manual.

| PROBLEMS (SYMPTOMS) | POSSIBLE AREAS OF MISADJUSTMENT(S) | RECOMMENDED COURSE OF ACTION |
|--|---|---|
| FUNCTION PROBLEMS | | |
| <p>The ammeter on the POWER FEED® 25M does not function properly even though the STATUS LEDs are steady green.</p> | <ol style="list-style-type: none"> 1. Make sure the DIP switches are configured correctly for the welding process and polarity used. See Setting DIP Switches in the Wire Drive in the Installation section of this manual. 2. Check the following connections on the POWER WAVE® machine. Check for loose or faulty connections between plug J90 at the current transducer and plug J21 on the Power Source control board. | <ol style="list-style-type: none"> 1. Perform the Current Transducer Test in the Power Source Service Manual. 2. The control board, located in the power source, may be faulty. |
| <p>The display and/or indicator LEDs do not change when their corresponding switches and or knobs are activated or turned.</p> | <ol style="list-style-type: none"> 1. Check for loose or faulty connections between the encoder panel and the Control Box control board. 2. Check for loose or faulty connections between the appropriate switches and the Control Box control board. | <ol style="list-style-type: none"> 1. Check suspected potentiometer and/or switches for correct resistances and operation. 2. Refer to machine schematics for lead numbers and voltages. 3. The Control Box control board may be faulty. |
| <p>The mode and/or settings change while welding under normal conditions.</p> | <ol style="list-style-type: none"> 1. Contact "powerwave software.com" for the latest updated software. | |
| | | |

⚠ CAUTION

If for any reason you do not understand the test procedures or are unable to perform the tests/repairs safely, contact the Lincoln Electric Service Department for technical troubleshooting assistance before you proceed. Call 1-888-935-3877.



Return to Section TOC

Return to Master TOC

Observe Safety Guidelines detailed in the beginning of this manual.

| PROBLEMS (SYMPTOMS) | POSSIBLE AREAS OF MISADJUSTMENT(S) | RECOMMENDED COURSE OF ACTION |
|---|--|---|
| FUNCTION PROBLEMS | | |
| The wire feed speed is consistent and adjustable, but runs at the wrong speed. | 1. The DIP switch on the wire drive unit may not be set for the correct gear ratio. See the Installation section of this manual. | 1. The feed head control board may be faulty. 2. The wrong gear may be installed. |
| The unit shuts off while welding or attempting to weld. The STATUS LED is alternating between red and green every second. The unit tries to recover after 30 seconds and may repeat sequence. | 1. The drive motor may be overloaded due to a mechanical restriction in the wire feeding path. See Operation section of this manual. | 1. If there are no restrictions in the wire feeding path, the drive motor or gear box may be faulty. 2. The feed head control board may be faulty. |
| | | |

⚠ CAUTION

If for any reason you do not understand the test procedures or are unable to perform the tests/repairs safely, contact the Lincoln Electric Service Department for technical troubleshooting assistance before you proceed. Call 1-888-935-3877.

POWER FEED® 25M



Return to Section TOC

Return to Master TOC

Observe Safety Guidelines detailed in the beginning of this manual.

| PROBLEMS (SYMPTOMS) | POSSIBLE AREAS OF MISADJUSTMENT(S) | RECOMMENDED COURSE OF ACTION |
|--|---|--|
| OUTPUT PROBLEMS | | |
| The feeder does power up - no display, no cold feed. | <ol style="list-style-type: none"> 1. The POWER FEED® 25M power switch is OFF. 2. The Power Wave power source is OFF. 3. The circuit breaker for the wire feeder on power source have tripped. 4. The control cable may be loose or damaged. 5. The power switch is damaged. | <ol style="list-style-type: none"> 1. Turn the POWER FEED® 25M power switch ON. 2. Turn ON the Power Wave power source. 3. Reset the circuit breakers. 4. Tighten, repair or replace the control cable. 5. Replace the power switch. |
| No shielding gas. | <ol style="list-style-type: none"> 1. The gas supply is OFF or empty. 2. The gas hose is cut or crushed. 3. Dirt or debris is in the solenoid. 4. There is a loose solenoid connection or the solenoid has failed. | <ol style="list-style-type: none"> 1. Verify the gas supply is ON and flowing. 2. Route the gas hose so it avoids sharp corners and make sure nothing is on top of it. Repair or replace damaged hoses. 3. Apply filtered shop air at 80psi to the solenoid to remove dirt. 4. Remove the cover and check that all connections are in good condition. |
| Inconsistent wire feeding or wire not feeding but drive rolls turning. | <ol style="list-style-type: none"> 1. The gun cable is kinked and/or twisted 2. The wire is jammed in the gun and cable. 3. The gun liner is dirty or worn. 4. The electrode is rusty or dirty. 5. The contact tip is partially melted or has spatter. 6. Improper gun liner, tip, drive rolls and/or inner wire guide. 7. Incorrect tension arm pressure on the drive rolls. 8. Worn drive roll. | <ol style="list-style-type: none"> 1. Keep the gun cable as straight as possible. Avoid sharp corners or bends in the cable. 2. Remove the gun from the wire feeder and pull the jammed wire out of the gun and cable. 3. Blow dirt out of the liner with low pressure (40psi or less). Replace the liner if worn. 4. Use only clean electrode. Use quality electrode, like L-50 or L-56 from Lincoln Electric. 5. Replace the contact tip. 6. Verify the proper parts are installed. 7. Adjust the tension arm per the Instruction Manual. Most electrodes feed well at a tension arm setting of "3". 8. Replace the drive rolls if worn or filled with dirt. |

⚠ CAUTION

If for any reason you do not understand the test procedures or are unable to perform the tests/repairs safely, contact the Lincoln Electric Service Department for technical troubleshooting assistance before you proceed. Call 1-888-935-3877.

POWER FEED® 25M



Observe Safety Guidelines detailed in the beginning of this manual.

| PROBLEMS (SYMPTOMS) | POSSIBLE AREAS OF MISADJUSTMENT(S) | RECOMMENDED COURSE OF ACTION |
|---|--|--|
| OUTPUT PROBLEMS | | |
| Variable or "hunting" arc. | <ol style="list-style-type: none"> 1. Wrong size, worn and/or melted contact tip. 2. Worn work cable or poor work connection. 3. Wrong polarity. 4. The gas nozzle is extended beyond the contact tip or the wire stickout is too long. 5. Poor gas shielding on processes requiring gas. | <ol style="list-style-type: none"> 1. Replace the contact tip. 2. Verify all work and electrode connections are tight and that the cables are in good condition. Clean/replace as necessary. 3. Adjust polarity to the recommended procedure. 4. Adjust the gas nozzle and shorten the stickout to 3/8 to 1/2 inches. 5. Check gas flow and mixture. Remove or block sources of drafts. |
| Poor arc starts with sticking or "blast-offs", weld porosity, narrow and ropy looking bead. | <ol style="list-style-type: none"> 1. Improper procedures or techniques. | <ol style="list-style-type: none"> 1. See "Gas Metal Arc Welding Guide" (GS-100). |
| <p>The wire feed speed/amperage and voltage/trim display work during preset but show nothing during welding.</p> <p>Can only select mode 12 or other (Factory Reset) setting - or unit returns to the factory setting</p> | <ol style="list-style-type: none"> 1. The software in the POWER FEED® 25M must be upgraded. | <ol style="list-style-type: none"> 1. Contact the local authorized Lincoln Field Service Shop. 2. Download update from powerwavesoftware.com |

⚠ CAUTION

If for any reason you do not understand the test procedures or are unable to perform the tests/repairs safely, contact the Lincoln Electric Service Department for technical troubleshooting assistance before you proceed. Call 1-888-935-3877.

POWER FEED® 25M



Observe Safety Guidelines detailed in the beginning of this manual.

| PROBLEMS (SYMPTOMS) | POSSIBLE AREAS OF MISADJUSTMENT(S) | RECOMMENDED COURSE OF ACTION |
|---|--|--|
| FUNCTION PROBLEMS | | |
| Major physical or electrical damage is evident when the sheet metal cover(s) are removed. | 1. Contact your local authorized Lincoln Electric Field Service Facility for assistance. | 1. Contact the Lincoln Electric Service Department, 1-888-935-3877. |
| No wire feed, solenoid or arc voltage. The STATUS LED's are steady green. | 1. The gun trigger may be faulty. Check or replace. 2. Check panel connections and switch(s) for proper operation. | 1. Check the continuity of leads from the gun trigger receptacle to plug J85. See wire drive wiring diagram. 2. The wire drive feedhead board may be faulty. |
| No control of wire feed speed. All STATUS LEDs are steady green. The preset wire feed speed is adjustable on the front panel. | 1. Check P9 plug and set at feedhead control. | 1. Perform the Tach Feedback Test . 2. The wire drive feedhead board may be faulty. |
| No welding arc voltage when the gun trigger is activated. The wire feeds normally and the gas solenoid functions properly. The STATUS LEDs are steady green on the wire drive unit. | 1. The Power source may be unable to produce welding output due to a thermal fault or other malfunction. Check STATUS LED on Power Source. See PowerWave® Troubleshooting. | 1. Make certain the Power Wave power source is functioning correctly. (Green Status LED) 2. Check weld + work cable routing. |
| The wire feed speed does not change when welding current is established. The WFS stays at the run-in speed. The STATUS LEDs are steady green. | 1. The run in and weld wire feed speeds may be set to the same value. Set run in speed to a value that gives best starting results. | 1. Perform the Current Transducer Test in POWERWAVE® service manual. 2. If the run in wire feed speed cannot be adjusted, perform the Tach Feedback Test and also the Drive Motor Test . 3. The wire drive feedhead board may be faulty. |

⚠ CAUTION

If for any reason you do not understand the test procedures or are unable to perform the tests/repairs safely, contact the Lincoln Electric Service Department for technical troubleshooting assistance before you proceed. Call 1-888-935-3877.

POWER FEED® 25M



Observe Safety Guidelines detailed in the beginning of this manual.

| PROBLEMS (SYMPTOMS) | POSSIBLE AREAS OF MISADJUSTMENT(S) | RECOMMENDED COURSE OF ACTION |
|---|---|--|
| FUNCTION PROBLEMS | | |
| <p>The purge switch does not activate the gas solenoid, but gun trigger closure in the MIG or pulse modes does activate the solenoid. The LEDs are steady green on the power source, and wire drive unit.</p> | <ol style="list-style-type: none"> 1. Make certain the COLD INCH/GAS PURGE switch is operating properly. 2. Check for loose or faulty leads between COLD INCH/GAS PURGE switch and the feedhead board. See wiring diagram. | <ol style="list-style-type: none"> 1. If the COLD INCH/GAS PURGE switch is operating correctly and the associated leads are OK. The feedhead board may be faulty. |
| <p>The COLD INCH/GAS PURGE switch does not turn on the wire drive motor but gun trigger closure in the MIG or Pulse modes does activate the wire drive motor. The LEDs are steady green on the power source, and wire drive unit.</p> | <ol style="list-style-type: none"> 1. Make certain the COLD INCH/GAS PURGE switch is operating properly. 2. Check for loose or faulty leads between the COLD INCH/GAS PURGE switch and the feedhead board. See wiring diagram. | <ol style="list-style-type: none"> 1. If the COLD INCH/GAS PURGE switch is operating correctly and the associated leads are OK. The feedhead board may be faulty. |
| <p>The voltmeter on the wire feeder does not function properly even though the STATUS LEDS are steady green.</p> | <ol style="list-style-type: none"> 1. Make sure the DIP switches are configured correctly for the welding polarity being used. See Setting Dip Switches in the Wire Drive in the Installation section of this manual. 2. Check the #67 lead on the wire drive unit. Make sure it is connected to the motor gear box and also the voltage sense PC board. 3. Check the work sensing leads on the POWER FEED® 25M power source. Check leads #202 (Neg. output terminal) and #206 (pos. output terminal). See POWER FEED® 25M wiring diagram. If external voltage sensing is utilized, Check the #21 lead between the 4-pin receptacle on the front of the POWERWAVE® and the work-place. | <ol style="list-style-type: none"> 1. Check leads #513 and #514 from J85 on the feedhead board to the voltage sense PC board. Verify placement in proper cavities. 2. Perform the Voltage Sense Board Test. 3. The display board may be faulty. 4. The feedhead control board may be faulty. 5. The Control Box control board may be faulty. |

⚠ CAUTION

If for any reason you do not understand the test procedures or are unable to perform the tests/repairs safely, contact the Lincoln Electric Service Department for technical troubleshooting assistance before you proceed. Call 1-888-935-3877.

Return to Section TOC
Return to Master TOC

Observe Safety Guidelines detailed in the beginning of this manual.

| PROBLEMS (SYMPTOMS) | POSSIBLE AREAS OF MISADJUSTMENT(S) | RECOMMENDED COURSE OF ACTION |
|--|--|---|
| FUNCTION PROBLEMS | | |
| <p>The displays are blank (not lit). The wire feeds when the gun trigger is activated.</p> | <p>1. Check for loose or faulty connections at plug on the display board, to plug on the memory board to the plug on the msp-4 board to the plug on the push-pull daughter board to the feed head board.</p> | <p>1. Check for 5VDC at J37 pins 2 and 10 on the display board. If 5 VDC is present, then the display board may be faulty.</p> <p>2. If the 5VDC is low or not present, check for loose or faulty connections in SPI circuit. See machine schematic.</p> <p>3. The feedhead control board may be faulty.</p> |
| <p>The dual procedure is not functional when using the remote Dual Procedure switch. The STATUS LEDs are steady green on the power source, and wire drive units.</p> | <p>1. Make certain the LED indicator on the Dual Procedure Panel is in the middle position. This enables the gun remote dual procedure switch.</p> | <p>1. Check shielded cable lead and connections from J86 on PC BD to MSP panel. Check SPI cable from MSP panel to Dual/memory panel. Per machine schematic.</p> <p>2. Check for 5VDC at J86 pins 2 and 10. Check for 15VDC at J86 pins 1 and 10. If voltage is not present replace feed head. If leads and voltages are good replace dual/memory panel.</p> |

⚠ CAUTION

If for any reason you do not understand the test procedures or are unable to perform the tests/repairs safely, contact the Lincoln Electric Service Department for technical troubleshooting assistance before you proceed. Call 1-888-935-3877.

Return to Section TOC

Return to Master TOC

Observe Safety Guidelines detailed in the beginning of this manual.

| PROBLEMS (SYMPTOMS) | POSSIBLE AREAS OF MISADJUSTMENT(S) | RECOMMENDED COURSE OF ACTION |
|--|---|---|
| ArcLink System Error Codes | | |
| Fault Code | Description | Possible Adjustments |
| Err 81 Motor overload, long term. | 1. The wire drive motor has overheated. | <ol style="list-style-type: none"> 1. Check that the electrode slides easily through the gun and cable. 2. Remove tight bends from the gun and cable. 3. Check that the spindle brake is not too tight. 4. Verify a high quality electrode is being used. 5. Wait for the error to reset and the motor to cool (approximately 1 minute). |
| Err 82 Motor overload, short term. | 1. The wire drive motor current draw has exceeded limits, usually because the motor is in a locked rotor state. | <ol style="list-style-type: none"> 1. Check that motor can turn freely when idle arm is open. 2. Verify that the gears are free of debris and dirt. |
| Err 263 No usable weld modes. | 1. The power source does not have any welding programs loaded. | 1. See the power source Instruction Manual for load welding programs. |
| Err 53 Voltage sense loss. | 1. The system detected that one of the voltage sense lead cables was disconnected from the welding circuit during a weld. | Verify that leads 67 and 21 is enabled and connected. See enhanced schematic. |
| Err 95 Spool gun or pull gun motor overload. | 1. The drive motor in the spool gun or push-pull gun is drawing too much current. | Check spool gun brake or feeding for binding. Replace spool gun circuit board. |

⚠ CAUTION

If for any reason you do not understand the test procedures or are unable to perform the tests/repairs safely, contact the Lincoln Electric Service Department for technical troubleshooting assistance before you proceed. Call 1-888-935-3877.

POWER FEED® 25M



Return to Section TOC
Return to Master TOC

Return to Section TOC
Return to Master TOC

Return to Section TOC
Return to Master TOC

Return to Section TOC
Return to Master TOC

POWER FEED 25M



VOLTAGE SENSE PC BOARD TEST**⚠ WARNING**

Service and repair should be performed by only Lincoln Electric factory trained personnel. Unauthorized repairs performed on this equipment may result in danger to the technician or machine operator and will invalidate your factory warranty. For your safety and to avoid electrical shock, please observe all safety notes and precautions detailed throughout this manual.

If for any reason you do not understand the test procedures or are unable to perform the test/repairs safely, contact the Lincoln Electric Service Department for electrical troubleshooting assistance before you proceed. Call 1-888-935-3877.

TEST DESCRIPTION

This test will help determine if the voltage sensing board is receiving the correct activation signal from the control board and also if the voltage sensing board is processing arc voltage sensing information.

MATERIALS NEEDED

3/8" in. nut driver
Volt-Ohm Meter

FIGURE F.1 – PLUG J1 AND J2 LOCATIONS

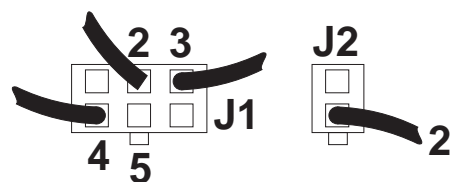

NOTE: Inspect the molex plug connector pins on the Voltage Sense Board. If any of them are gold plated the P.C. board should be replaced.

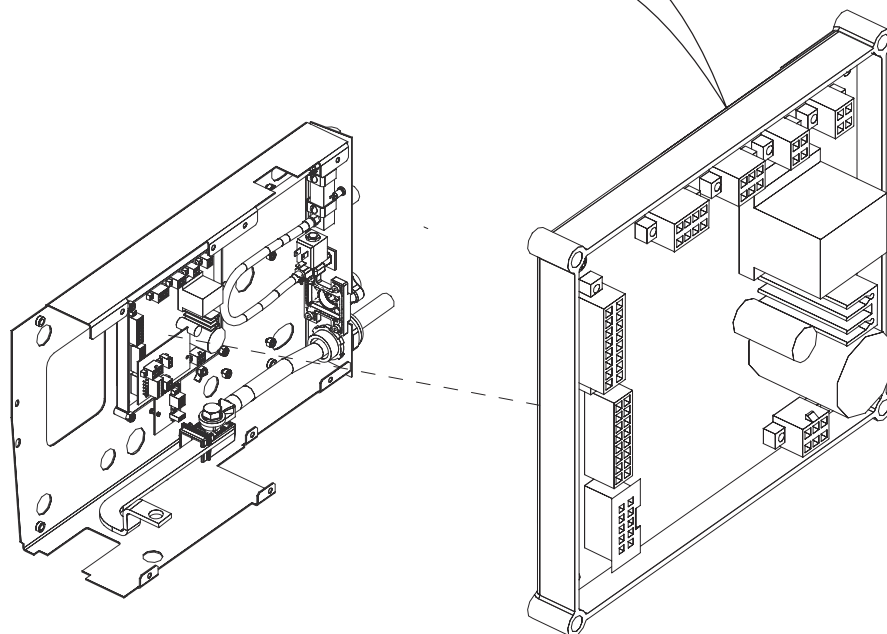

PROCEDURE

1. Remove input power from the wire feed unit.
2. Using the 3/8 in. nut driver, remove the cover from behind the wire reel.
3. Locate the voltage sense PC board and plugs J1 and J2. Do not remove the plugs from the voltage sense pc board. Refer to Figure F.1.
4. Apply the correct input power (from the POWER FEED® 25M control cable) to the wire feeder. With the gun trigger activated, check for approximately 12 VDC at plug J1 pin 1 (+) to pin 4 (-). If the 12 VDC is NOT present, the feedhead board may be faulty. Also check for trigger closure at J85 pins 1 & 2 on feedhead board and loose or faulty wires and connections between the feedhead board (plug J85 and plug J1 on the voltage sense PC board). This voltage is polarity sensitive.
5. With the gun trigger activated and arc voltage present at the conductor block, check for arc voltage from plug J1 pin 3 (lead 67) to the workpiece. If actual arc voltage is NOT present, check the continuity of lead 67 from the conductor block to plug J1 pin 3 on the voltage sense PC board.
6. If the actual arc voltage IS present at plug J1 pin 3 (lead 67), then check for arc voltage from plug J2 pin 2 (lead 67B) to the workpiece. See wiring diagram.
7. If the 12 VDC IS present in step #4 and the arc voltage IS present in step #5 but the arc voltage is NOT present in step #6 (lead 67A), the voltage sense PC board may be faulty.
8. Remove all input power from the wire feeder unit.
9. Install the wire feeder cover with the 3/8 in. nut driver.

POWER FEED® 25M



TACH FEEDBACK TEST**⚠ WARNING**

Service and repair should be performed by only Lincoln Electric factory trained personnel. Unauthorized repairs performed on this equipment may result in danger to the technician or machine operator and will invalidate your factory warranty. For your safety and to avoid electrical shock, please observe all safety notes and precautions detailed throughout this manual.

If for any reason you do not understand the test procedures or are unable to perform the test/repairs safely, contact the Lincoln Electric Service Department for electrical troubleshooting assistance before you proceed. Call 1-888-935-3877.

TEST DESCRIPTION

This test will determine if the tach unit is receiving the correct supply voltage from the control board, and also if the tach unit is sending feedback information to the control board.

MATERIALS NEEDED

3/8" in. nut driver
Volt-Ohm Meter

TACH FEEDBACK TEST (continued)

FIGURE F.2 – PLUG J84 LOCATION

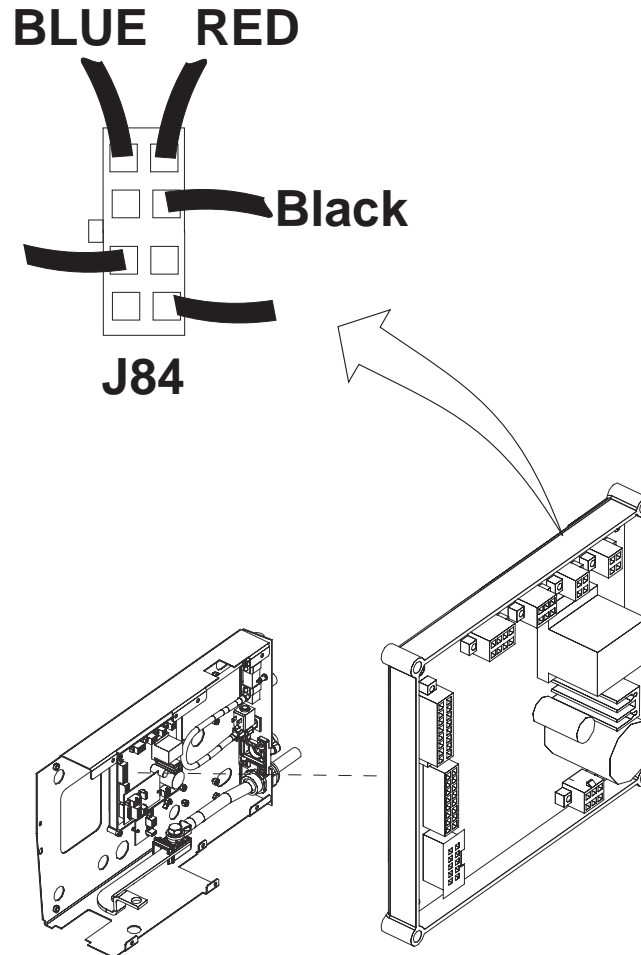

PROCEDURE

1. Remove input power from the wire feeder unit.
2. Using the 3/8 in. nut driver, remove the cover from behind wire reel.
3. Locate plug J84 on the feed head board. Refer to Figure F.2. Do Not remove the plug from the feed head board.
4. Apply the correct input power (from the POWER FEED® 25M control cable) to the wire feeder unit and check for approximately 5VDC from (red wire) positive to (black wire) negative. This is the supply voltage from feedhead board to the tach feedback unit. If the 5VDC is missing or not correct, the feedhead board may be faulty. Also check for loose or faulty wires and connections.
5. With the gun trigger activated and the motor running, check the feedback voltage at plug J84 (blue wire) positive to (black wire) negative. Normal feedback voltage is approximately 2 VDC. If the correct supply voltage is present and the feedback voltage is missing, the tach unit may be faulty. With the motor NOT running, the feedback voltage may be either 0 or 5 VDC depending upon where the motor stopped.
6. Remove input power from the wire feeder unit.
7. Install the wire feeder cover with the 3/8 in. nut driver.

POWER FEED® 25M



DRIVE MOTOR TEST**⚠ WARNING**

Service and repair should be performed by only Lincoln Electric factory trained personnel. Unauthorized repairs performed on this equipment may result in danger to the technician or machine operator and will invalidate your factory warranty. For your safety and to avoid electrical shock, please observe all safety notes and precautions detailed throughout this manual.

If for any reason you do not understand the test procedures or are unable to perform the test/repairs safely, contact the Lincoln Electric Service Department for electrical troubleshooting assistance before you proceed. Call 1-888-935-3877.

TEST DESCRIPTION

This test will determine if the wire drive motor is receiving the correct voltage, and if it is capable of running properly.

MATERIALS NEEDED

3/8" in. nut driver
Volt-Ohmmeter

DRIVE MOTOR TEST (continued)

FIGURE F.3 – QUICK CONNECTOR #550 AND #551 LOCATIONS

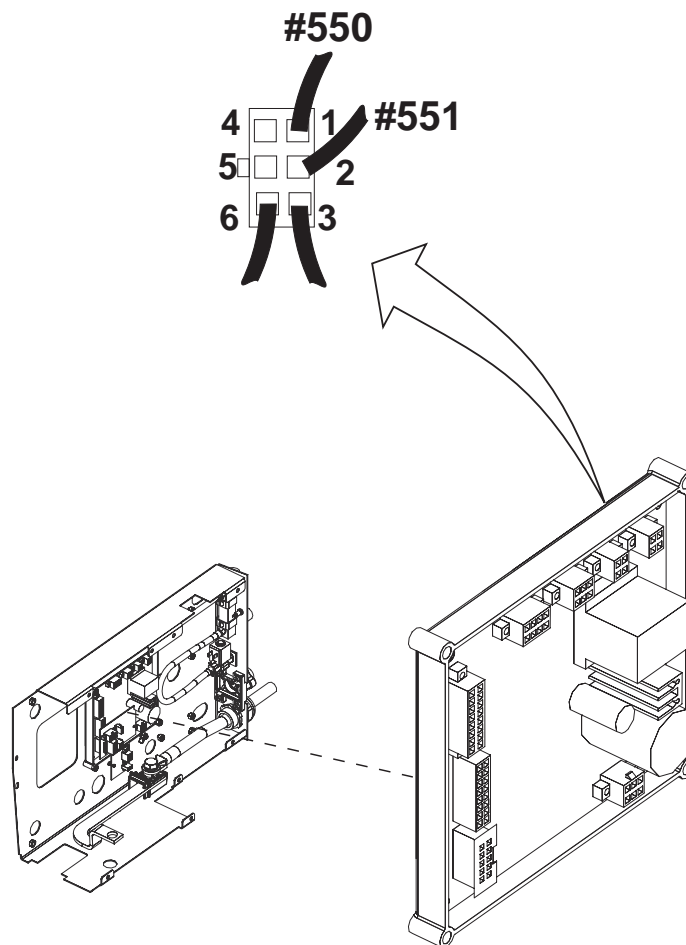

PROCEDURE

1. Remove input power to wire feed unit.
2. Using the 3/8 in. nut driver, remove the cover from the wire feeder.
3. Locate the two quick connectors in the two motor armature leads. Refer to Figure F.3. Do NOT disconnect the leads.
4. Apply the correct input power (from the POWER FEED® 25M control cable) to the wire feeder. Activate the gun trigger and with the motor running check at the quick connectors [#550 White (+) to #551 / Black (-)] for approximately 1 VDC to 32 VDC dependent upon motor speed. The motor speed should vary with changes in motor armature voltage.
5. If the correct voltages are NOT present at the motor leads, check the associated leads between the motor and plug J83 on the feedhead board. If the leads are OK, the feedhead board may be faulty.
6. If the correct voltages are present at motor armature leads and the motor does not run and vary speed with changes in armature voltage, the motor or gear box may be faulty. See **Gear Box and Drive Motor Removal and Replacement**.
7. Install the wire feeder cover using the 3/8 in. nut driver.

GEAR BOX AND DRIVE MOTOR REMOVAL AND REPLACEMENT PROCEDURE

WARNING

Service and repair should be performed by only Lincoln Electric factory trained personnel. Unauthorized repairs performed on this equipment may result in danger to the technician or machine operator and will invalidate your factory warranty. For your safety and to avoid electrical shock, please observe all safety notes and precautions detailed throughout this manual.

If for any reason you do not understand the test procedures or are unable to perform the test/repairs safely, contact the Lincoln Electric Service Department for electrical troubleshooting assistance before you proceed. Call 1-888-935-3877.

TEST DESCRIPTION

This test will aid the technician in the removal and replacement of the wire feed drive motor.

MATERIALS NEEDED

- 3/8 in. nut driver
- Slot head screwdriver
- Phillips head screwdriver
- 7/16 in. socket wrench with extension
- Needlenose pliers
- 5/16 in. wrench
- 3/16 in. Allen wrench

GEAR BOX REMOVAL AND DRIVE MOTOR REMOVAL AND REPLACEMENT PROCEDURE (continued)

FIGURE F.4 – GEAR BOX AND DRIVE MOTOR REMOVAL AND REPLACEMENT

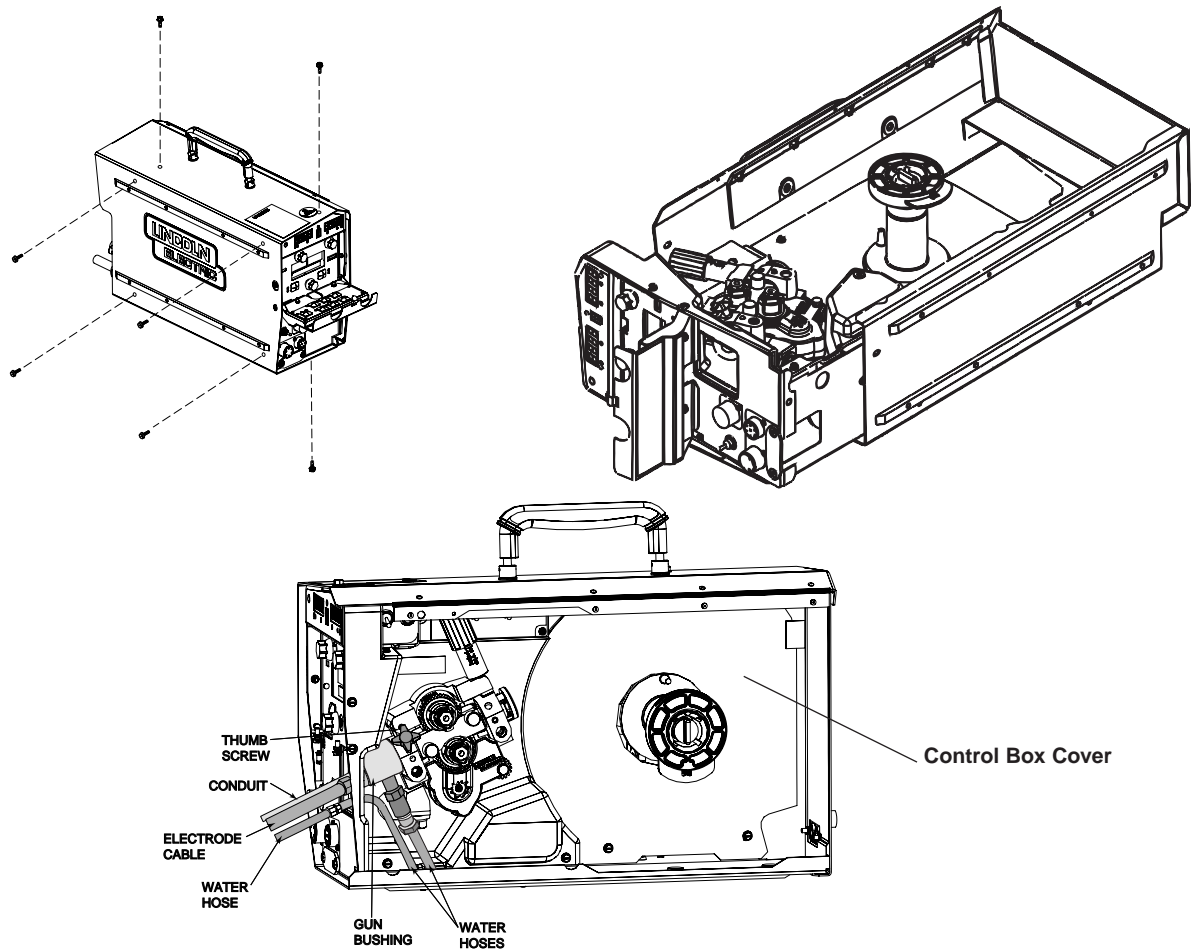

PROCEDURE

1. Remove input power to wire feed unit.
2. Using the 3/8 in. nutdriver, remove the case cover.
3. Locate and remove plug J84 from the feedhead - control board, located under control box cover Refer to figure F.4.
4. Thread plug J84 and associated leads through the vertical baffle. Cut any necessary cable ties.
5. Locate and disconnect the motor leads (#551 and #550) at the quick connects. Cut any necessary cable ties.
6. Using the Phillips head screwdriver, remove the #67 lead from the conductor block.
7. Using the needlenose pliers, disconnect the gas hose from the brass gun connector block.
8. Using the 7/16 in. socket wrench, remove the four mounting bolts, lock washers, and flat washers from the plastic base insulator.
9. Carefully slide and remove the entire gear box, drive motor, and wire drive assembly from the wire feeder case. Note insulation placement for reassembly.

POWER FEED® 25M



GEAR BOX REMOVAL AND DRIVE MOTOR REMOVAL AND REPLACEMENT PROCEDURE (continued)

TO REMOVE THE DRIVE MOTOR FROM THE GEAR BOX:

10. Using the slot head screwdriver, remove the gear box inspection cover nearest to the drive motor.
11. Using the 5/16 in. wrench, remove the motor mounting screw located inside the gear box.
12. Using the slot head screwdriver, remove the two screws mounting the "top" of the motor to the gear box.
13. Carefully remove the motor from the gear box assembly. Note motor lead placement for reassembly.

TO REMOVE THE WIRE DRIVE ASSEMBLY FROM THE GEAR BOX:

14. Using the 3/16 in. Allen wrench, loosen the two Allen type screws at the bottom of the wire drive unit.
15. Remove lead #67 from the conductor block.
16. Carefully slide and remove the wire drive assembly from the gear box assembly.

REPLACEMENT PROCEDURES

1. Carefully slide the wire drive assembly and gear box together.
2. Tighten the two Allen type screws at the bottom of the wire drive unit using the 3/16 in. Allen wrench.
3. Attach lead #67 to the conductor block.
4. Carefully slide the drive motor into the gear box assembly. Be sure to position the motor leads so that they can be properly connected.
5. Install the slot head screws that mount the

"top" of the drive motor to the gear box.

6. Install the mounting screw located inside the gearbox using the 5/16 in. wrench.
7. Install the gear box inspection cover and secure it with slot head screws.
8. Properly place insulation in the bottom of the wire feeder case.
9. Place the entire gear box, drive motor and wire drive assembly into the wire feeder case, aligning the holes in the plastic base insulator with the mounting holes in the case.
10. Mount the gear box and drive motor assembly to the wire feeder case using the four mounting bolts, lock washers and flat washers.
11. Connect the gas hose to the brass gun connector block.
12. Connect drive motor leads #550 and #551 to their quick disconnects.
13. Thread plug J4 and associated leads through the vertical baffle and attach it to the control board. Install cable ties as necessary.
14. Install the wire feeder cover using the 3/8 in. nut driver.

RETEST AFTER REPAIR

Retest a machine:

- If it is rejected under test for any reason that requires you to remove any part which could affect the machine's electrical characteristics.

OR

- If you repair or replace any electrical components.

SET UP

1. Once the repairs have been completed, the feeder must be connected to a Powerwave® 455M power source, or similar ArcLink® power source.
2. Go to the Service Navigator under Diagnostic Utility and perform the status check procedure.
3. With the use of a load bank and the utility, all functions of the feeder can be tested.

Electrical DiagramsG-1

 Wiring Diagram Entire Machine Code 11313 (G5585)G-2

 Schematic – Entire Machine - Code 11313 - (G5638)G-3

 Schematic - 42VAC & ArcLink Feeder PC Board #1 (Feeder PC Board) - Code 11313 - (G3883-1) ...G-4*

 Schematic - 42VAC & ArcLink Feeder PC Board #2 (Feeder PC Board) - Code 11313 - (G3883-1) ...G-5*

 Schematic – MSP4 Optional Display PC Board (G4456)G-6*

 Schematic - SPI Display PC Board - (L11756)G-7

 PC Board Assembly - SPI Display - (L11757-1)G-8

 Schematic – Voltage Sense Select PC Board - (S24779)G-9

 PC Board Assembly - Voltage Sense Select - (M19540)G-10

 Schematic - Spool Gun PC Board (L12008)G-11

 PC Board Assembly - Spool Gun (M20159)G-12

*** NOTE:** Many PC Board Assemblies are now totally encapsulated, surface mounted and or multi-layered and are therefore considered to be unserviceable. Assembly drawings of these boards are no longer provided.

Return to Master TOC

Return to Master TOC

Return to Master TOC

Return to Master TOC

WIRING DIAGRAM - COMPLETE MACHINE - CODE 11313 (G5585)

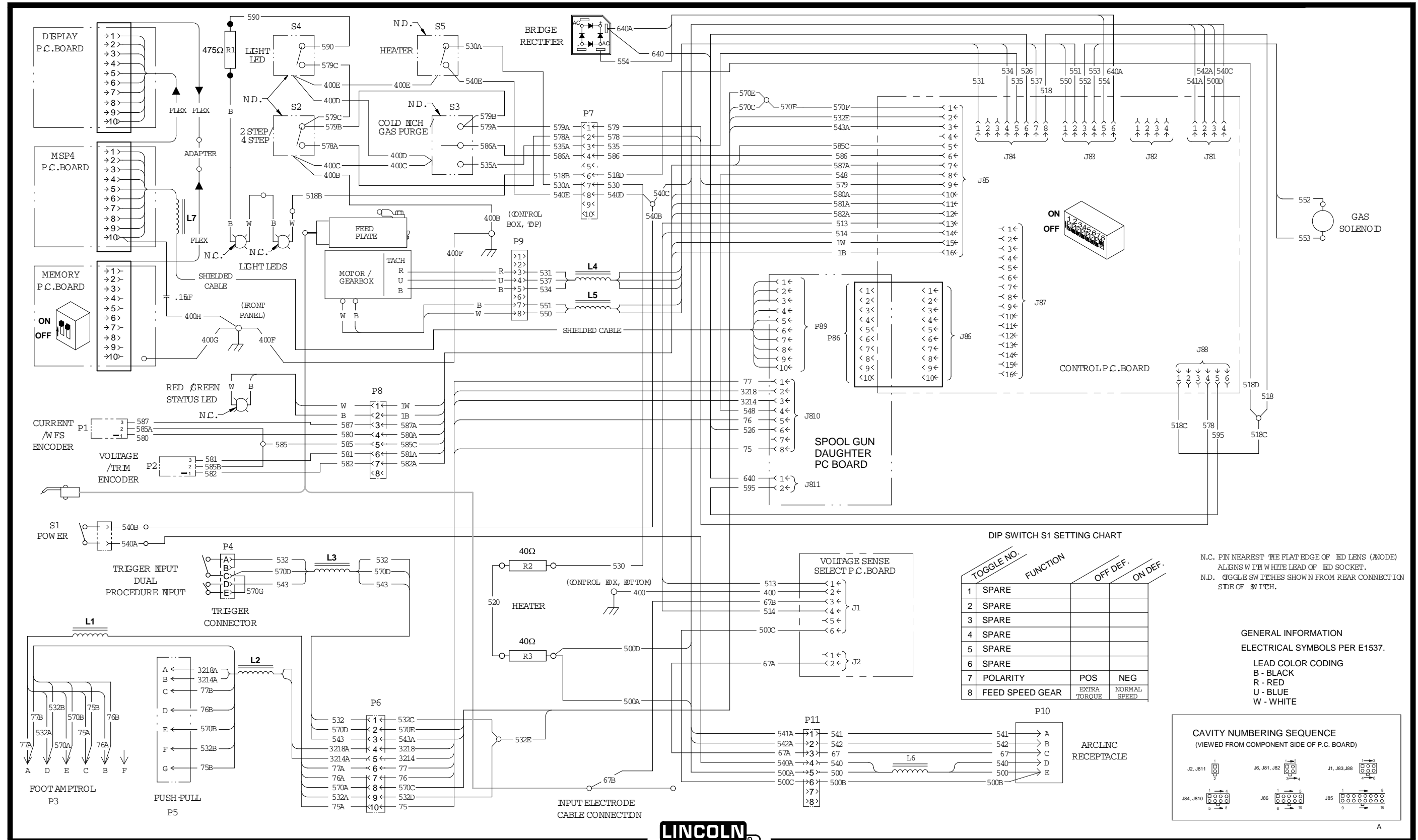

DIP SWITCH S1 SETTING CHART

| TOGGLE NO. | FUNCTION | OFF DEF. | ON DEF. |
|------------|-----------------|--------------|--------------|
| 1 | SPARE | | |
| 2 | SPARE | | |
| 3 | SPARE | | |
| 4 | SPARE | | |
| 5 | SPARE | | |
| 6 | SPARE | | |
| 7 | POLARITY | POS | NEG |
| 8 | FEED SPEED GEAR | EXTRA TORQUE | NORMAL SPEED |

N.C. PIN NEAREST THE FLAT EDGE OF LED LENS (ANODE) ALIGNS WITH WHITE LEAD OF LED SOCKET.
 N.D. TOGGLE SWITCHES SHOWN FROM REAR CONNECTION SIDE OF SWITCH.

GENERAL INFORMATION
 ELECTRICAL SYMBOLS PER E1537.
 LEAD COLOR CODING
 B - BLACK
 R - RED
 U - BLUE
 W - WHITE

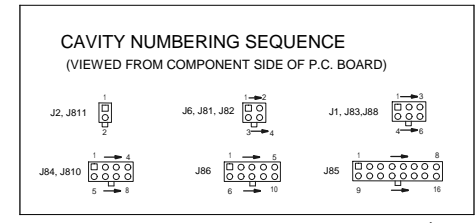

CLEVELAND, OHIO U.S.A.

G5585

NOTE: This diagram is for reference only. It may not be accurate for all machines covered by this manual. The wiring diagram specific to your code is pasted inside one of the enclosure panels of your machine.



Return to Section TOC

SCHEMATIC - COMPLETE MACHINE - CODE 11313 (G5638)

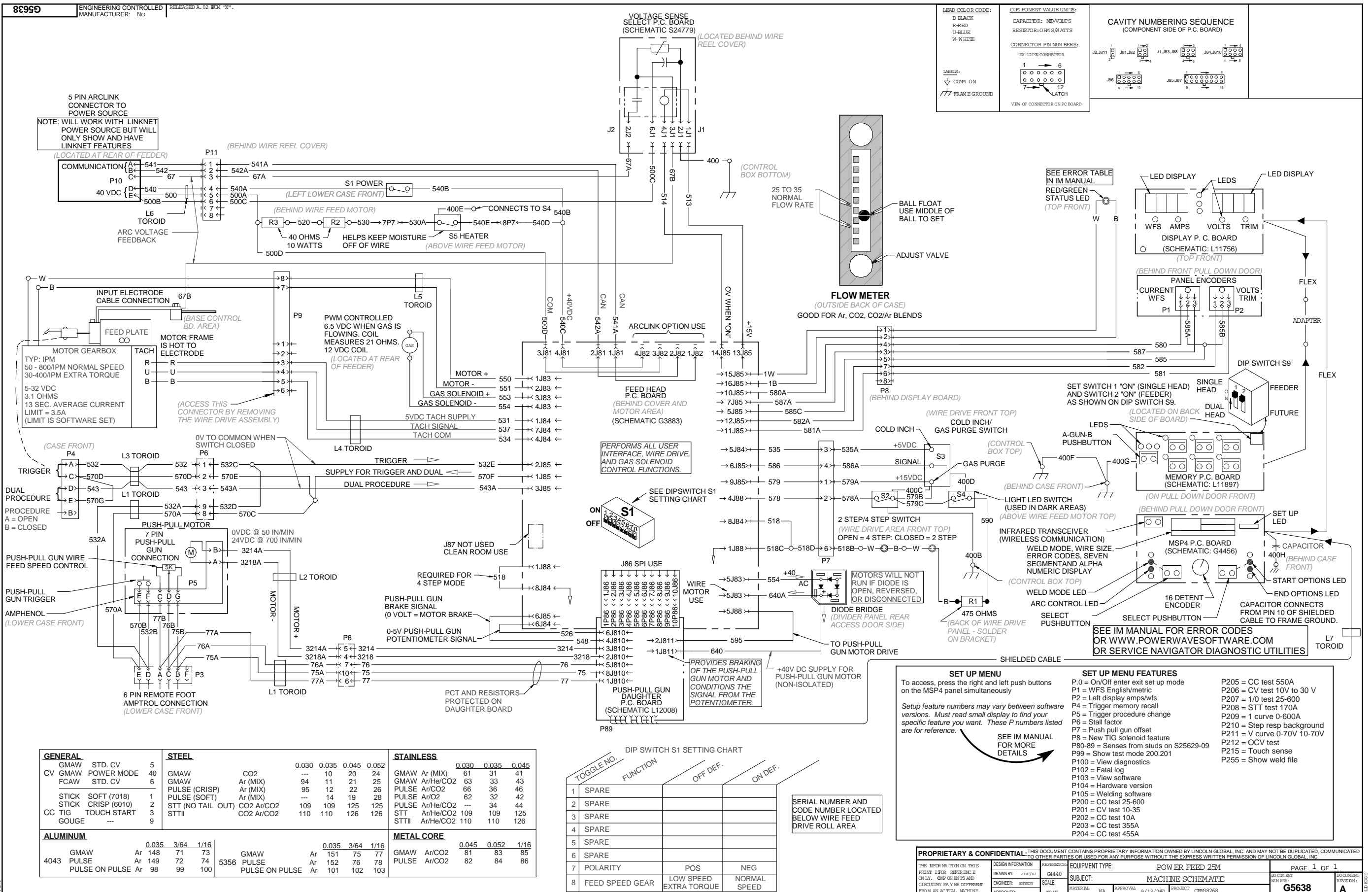

NOTE: This diagram is for reference only. It may not be accurate for all machines covered by this manual.

SCHEMATIC - 42 VAC & ARCLINK FEEDER PC BOARD #1 (G3883-2)

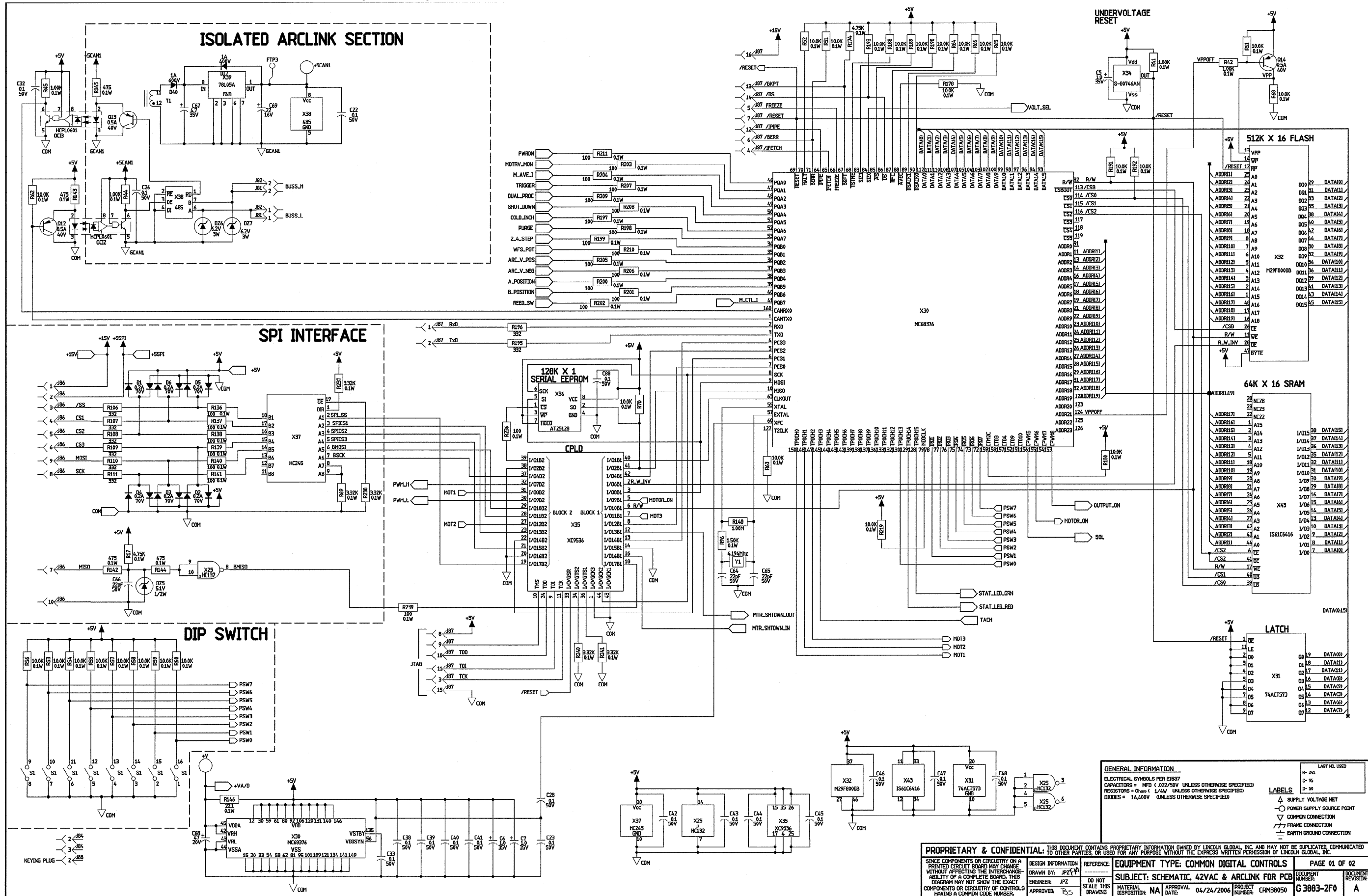

NOTE: This diagram is for reference only. It may not be accurate for all machines covered by this manual.

GENERAL INFORMATION

ELECTRICAL SYMBOLS PER IEC87
 CAPACITORS = MFD (0.22/50V UNLESS OTHERWISE SPECIFIED)
 RESISTORS = Ohms (1/4W UNLESS OTHERWISE SPECIFIED)
 DIODES = 1A,400V UNLESS OTHERWISE SPECIFIED

LABELS

▲ SUPPLY VOLTAGE NET
 ○ POWER SUPPLY SOURCE POINT
 ▽ COMMON CONNECTION
 ⊕ FRAME CONNECTION
 ⊕ EARTH GROUND CONNECTION

PROPRIETARY & CONFIDENTIAL THIS DOCUMENT CONTAINS PROPRIETARY INFORMATION OWNED BY LINCOLN GLOBAL, INC. AND MAY NOT BE DUPLICATED, COMMUNICATED TO OTHER PARTIES, OR USED FOR ANY PURPOSE WITHOUT THE EXPRESS WRITTEN PERMISSION OF LINCOLN GLOBAL, INC.

DESIGN INFORMATION DRAWN BY: JPZ
 ENGINEER: JPZ
 APPROVED: BS

REFERENCE EQUIPMENT TYPE: COMMON DIGITAL CONTROLS
 SUBJECT: SCHEMATIC, 42VAC & ARCLINK FDR PCB
 MATERIAL: NA
 DATE: 04/24/2006
 PROJECT NUMBER: CRM38050

PAGE 01 OF 02
 DOCUMENT NUMBER: G 3883-2F0
 REVISION: A

SCHEMATIC - 42 VAC & ARCLINK FEEDER PC BOARD #2 (G3883-2)

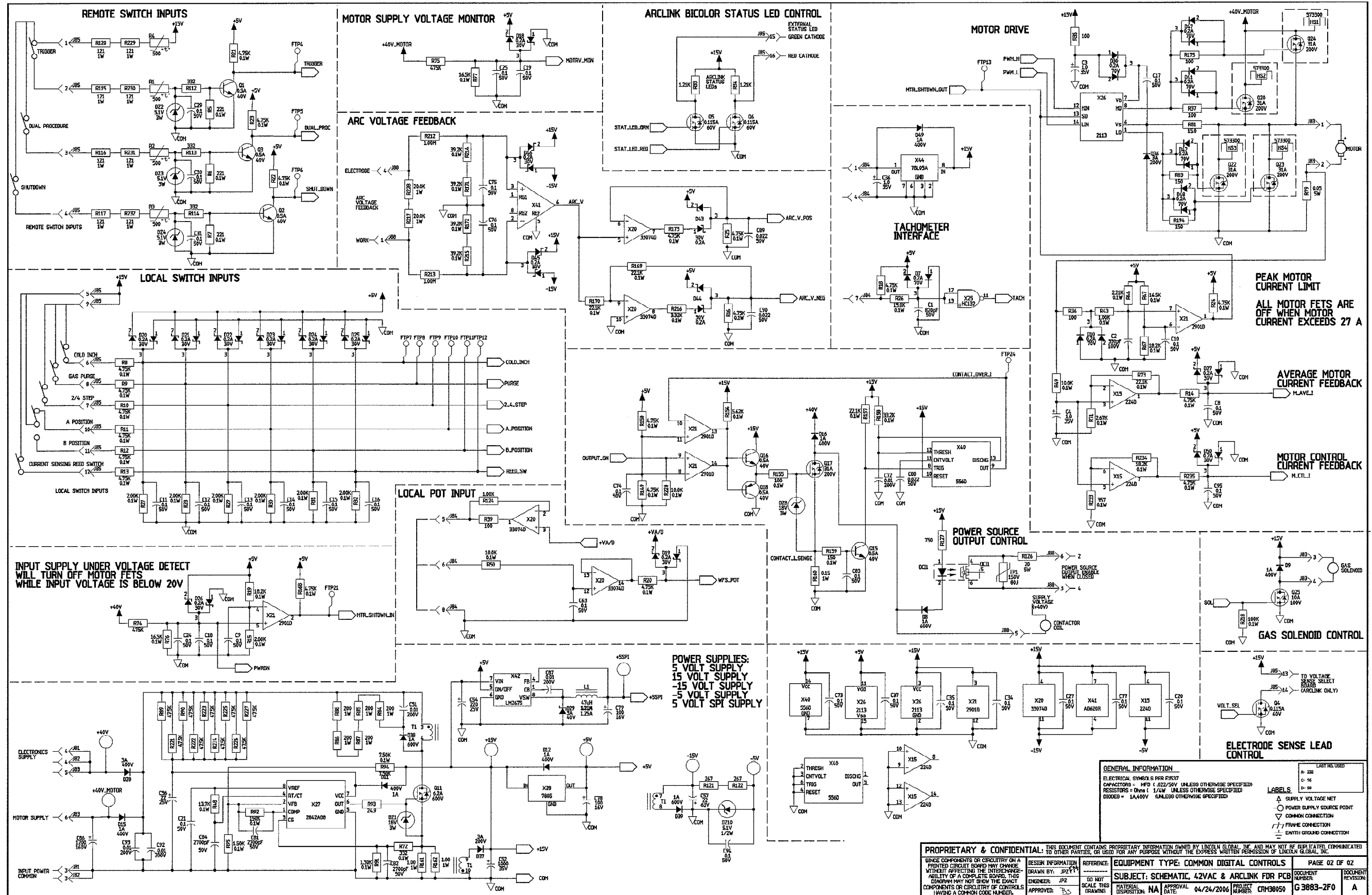

NOTE: This diagram is for reference only. It may not be accurate for all machines covered by this manual.

Return to Section TOC
Return to Master TOC
Return to Section TOC
Return to Master TOC
Return to Section TOC
Return to Master TOC
Return to Section TOC
Return to Master TOC

PROPRIETARY & CONFIDENTIAL: THIS DOCUMENT CONTAINS PROPRIETARY INFORMATION OWNED BY LINCOLN GLOBAL, INC. AND MAY NOT BE REPRODUCED OR TRANSMITTED IN ANY FORM OR BY ANY MEANS, ELECTRONIC OR MECHANICAL, INCLUDING PHOTOCOPYING, RECORDING, OR BY ANY INFORMATION STORAGE AND RETRIEVAL SYSTEM, WITHOUT THE EXPRESS WRITTEN PERMISSION OF LINCOLN GLOBAL, INC.

| | | | |
|--|---|--|--|
| DESIGN INFORMATION DRAWN BY: JP2 ENGINEER: JP2 APPROVED: BS | REFERENCE: DO NOT SCALE THIS DRAWING | EQUIPMENT TYPE: COMMON DIGITAL CONTROLS SUBJECT: SCHEMATIC, 42VAC & ARCLINK FDR PCB | PAGE 02 OF 02 DOCUMENT NUMBER: G3883-2F0 REVISION: A |
|--|---|--|--|

APPROVAL DATE: 04/24/2006
PROJECT NUMBER: CRH38050

SCHEMATIC - MSP4 OPTIONAL DISPLAY PC BOARD (G4456)

Return to Section TOC
Return to Master TOC

Return to Section TOC
Return to Master TOC

Return to Section TOC
Return to Master TOC

Return to Section TOC
Return to Master TOC

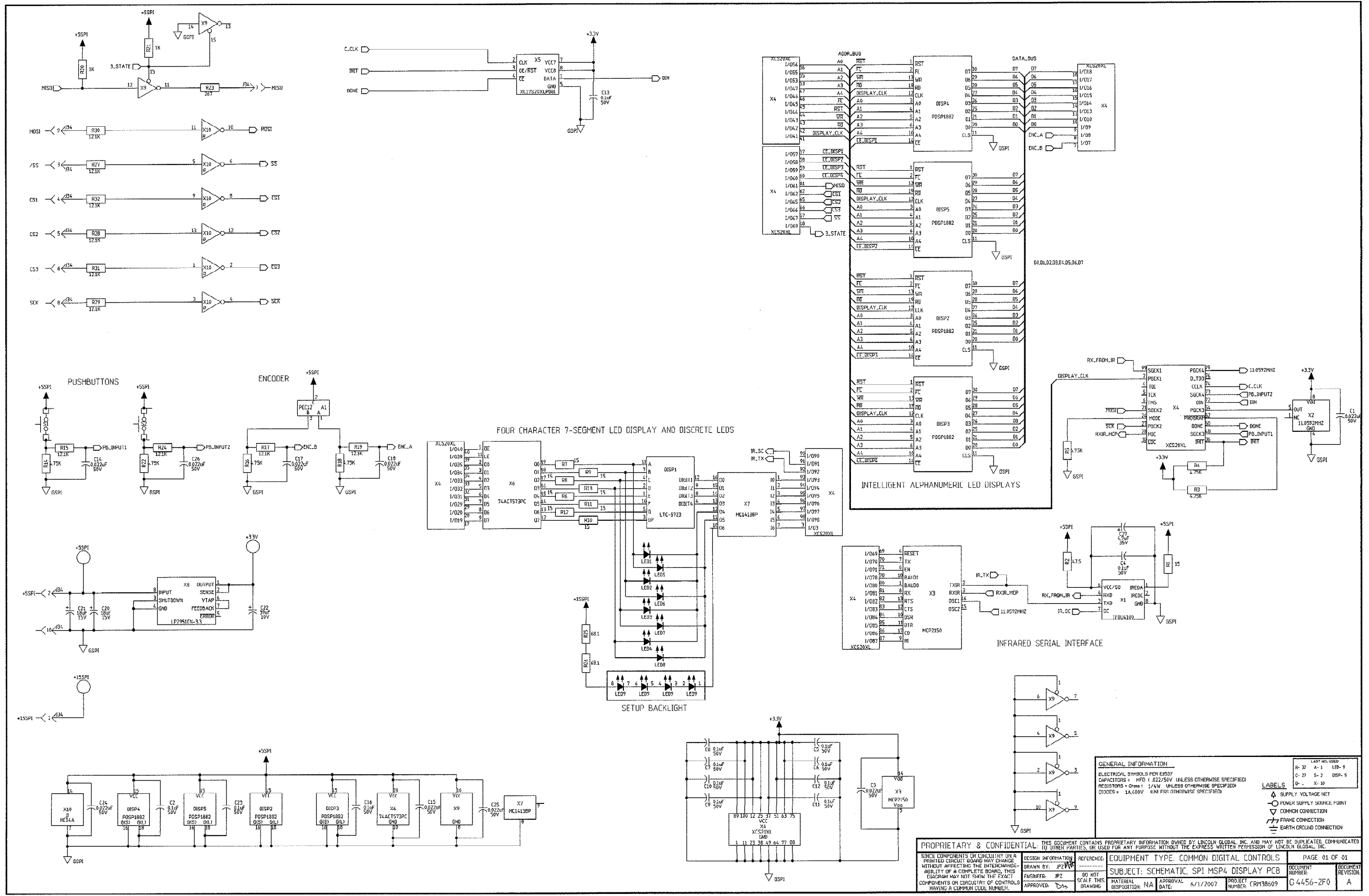

NOTE: This diagram is for reference only. It may not be accurate for all machines covered by this manual.

SCHEMATIC - SPI DISPLAY PC BOARD - (L11756)

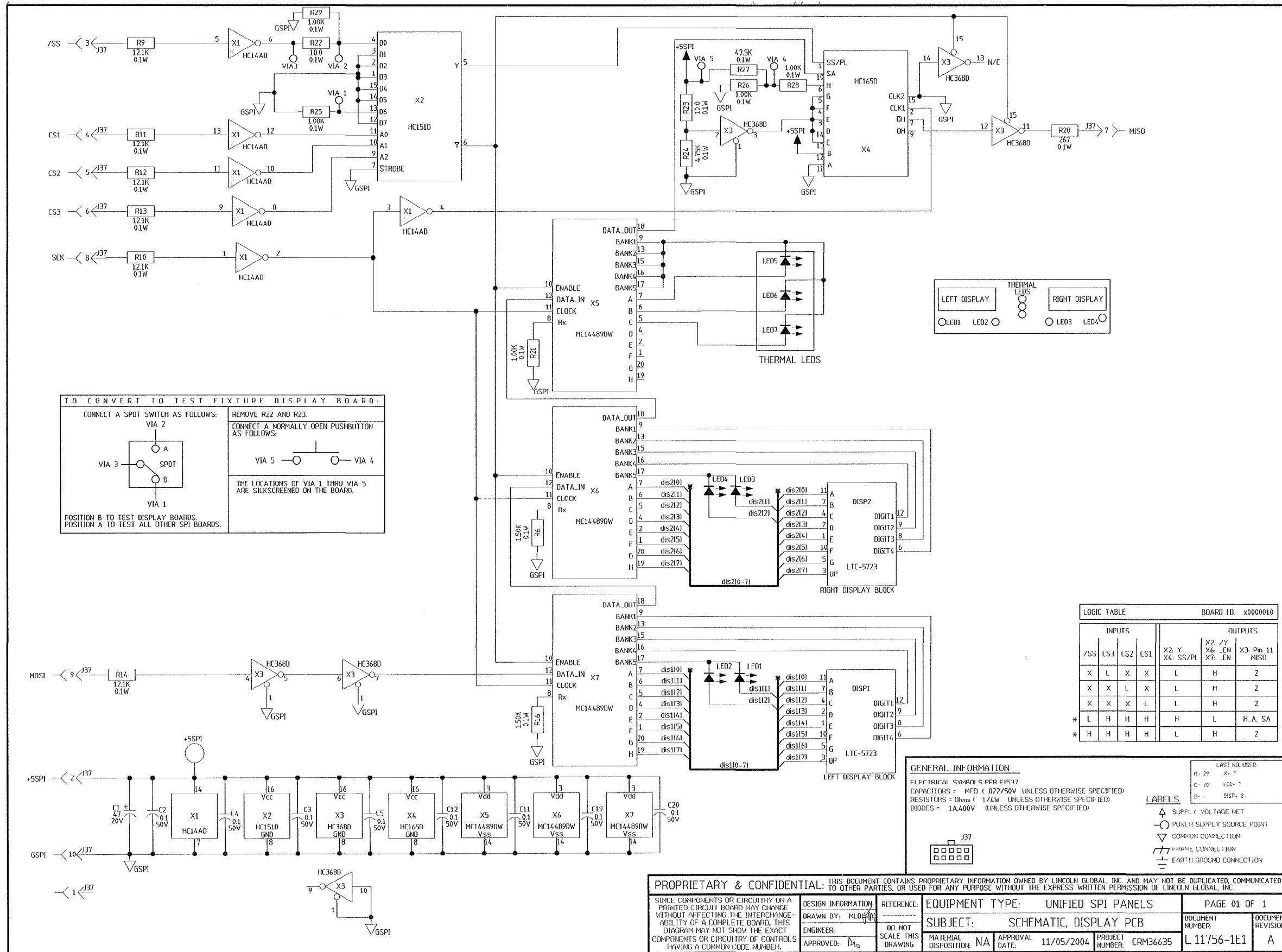

NOTE: This diagram is for reference only. It may not be accurate for all machines covered by this manual.

Return to Section TOC
Return to Master TOC
Return to Section TOC
Return to Master TOC
Return to Section TOC
Return to Master TOC
Return to Section TOC
Return to Master TOC

PC BOARD ASSEMBLY - SPI DISPLAY - (L11757-1)

Return to Section TOC
Return to Master TOC

Return to Section TOC
Return to Master TOC

Return to Section TOC
Return to Master TOC

Return to Section TOC
Return to Master TOC

| L11757-1 | | ENGINEERING CONTROL LED MANUFACTURER: Yes | CHANGE DETAIL: LED5, 6 & 7. REVISED PART NUMBER AND DESCRIPTION. REVISED IDENTIFICATION CODE AND SCHEMATIC REF. NUMBER. | |
|--|--------|--|---|--|
| ITEM / REFERENCE DESIGNATORS | QTY | PART NUMBER | DESCRIPTION | |
| 1 | 1 | L11757-E | P.C. BOARD BLANK | |
| 2 | 4 | T15176-2 | LED, SPACER, 0.140 HIGH | |
| 3 | .01 OZ | E3539 | ELECTRICAL INSULATING COMPOUND | |
| FOR ITEMS BELOW REFER TO ELECTRONIC COMPONENTS DATABASE FOR COMPONENT SPECIFICATIONS | | | | |
| C1 | 1 | S25024-7SMT | CAPACITOR,SMD,TANTALUM,47MF,20V,10%,S7343 | |
| C2, C3, C4, C5, C11, C12, C19, C20 | 8 | S25020-3SMT | CAPACITOR,SMD,CERAMIC,0.1MF,50V,10%,X7R,S0805 | |
| N.A., N.D. DISP1, DISP2 | 2 | S17395-9 | LED,DISPLAY,7-SEGMENT,CC,4-DIGIT | |
| J37 | 1 | S18248-10 | CONNECTOR,MOLEX,MINI,PCB,10-PIN | |
| N.C. LED1, LED2, LED3, LED4 | 4 | T13657-6 | LED,T-1,RED,HLMF-K101 | |
| N.A. LED5, LED6, LED7 | 3 | T13657-14 | LED,T-1,3/4,AMBER,HIGH-INTENSITY | |
| R6, R16 | 2 | S25000-1501SMT | RESISTOR,SMD,METAL FILM,1/10W,1.50K,1%,S0805 | |
| R9, R10, R11, R12, R13, R14 | 6 | S25000-1212SMT | RESISTOR,SMD,METAL FILM,1/10W,12.1K,1%,S0805 | |
| R20 | 1 | S25000-2670SMT | RESISTOR,SMD,METAL FILM,1/10W,2670HMS,1%,S0805 | |
| R21, R25, R26, R28, R29 | 5 | S25000-1001SMT | RESISTOR,SMD,METAL FILM,1/10W,1.00K,1%,S0805 | |
| R22, R23 | 2 | S25000-10R0SMT | RESISTOR,SMD,METAL FILM,1/10W,10.00HMS,1%,S0805 | |
| R24 | 1 | S25000-4751SMT | RESISTOR,SMD,METAL FILM,1/10W,4.75K,1%,S0805 | |
| R27 | 1 | S25000-4752SMT | RESISTOR,SMD,METAL FILM,1/10W,47.5K,1%,S0805 | |
| N.A. X1 | 1 | S17900-8SMT | IC,SMD,CMOS,INVERTER,SCHMITT,HEX,HC14A(SS) | |
| N.A. X2 | 1 | S17900-26SMT | IC,CMOS,SMD,MUX,DAT,8-INPUT,HC151(SS) | |
| N.A. X3 | 1 | S17900-28SMT | IC,SMD,CMOS,HEX INVERTING BUFFER,3-ST (SS) | |
| N.A. X4 | 1 | S17900-10SMT | IC,SMD,CMOS,REGISTER,SHFT,S-PI/SO,8-BIT(SS) | |
| N.A. X5, X6, X7 | 3 | S20496-1SMT | IC,SMD,CMOS,DRIVER,DISPLAY,LED,CC,MCU | |

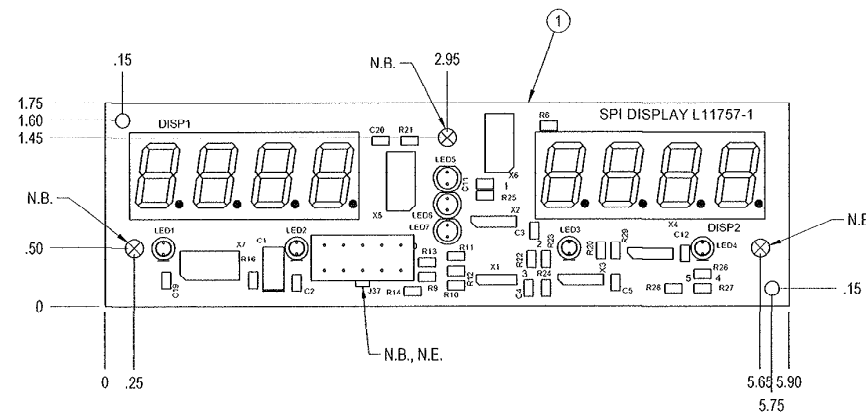

SCHEMATIC REFERENCE: L11756-1E1

UNLESS OTHERWISE SPECIFIED:
 CAPCITANCE = MFD/VOLTS
 RESISTANCE = OHMS
 INDUCTANCE = HENRIES

- NOTE:
- N.A. CAUTION: THIS DEVICE SUBJECT TO DAMAGE BY STATIC ELECTRICITY. SEE E2454 BEFORE HANDLING.
 - N.B. DO NOT COAT WITH ENCAPSULATION MATERIAL.
 - N.C. USE ITEM 2 TO STAND LED1, LED2, LED3 AND LED4 FROM THE P.C. BOARD. THERE MUST NOT BE MORE THAN .020 GAP BETWEEN SPACER AND P.C. BOARD OR BETWEEN SPACER AND LED. ENCAPSULATE P.C. BOARD, SPACER AND LOWER HALF OF LED.
 - N.D. DISP1 AND DISP2 MUST ALWAYS BE MATCHED BY VENDOR NAME. DO NOT MIX DIFFERENT VENDORS ON THE SAME BOARD ASSEMBLY. ENCAPSULATE LOWER HALF OF DISPLAYS ONLY, FACE AND UPPER HALF MUST BE FREE OF ENCAPSULATION.
 - N.E. CONNECTOR MUST BE GREASED WITH ITEM 3 PRIOR TO ENCAPSULATION.

BUY AS:
 L11757-1E1
 IDENTIFICATION CODE

ENCAPSULATE WITH HUMISEAL 1A27LU
 PER E1844 OR WITH EQUIVALENT AS
 APPROVED BY LINCOLN ELECTRIC COMPANY.
 (2 COATS)

BUY PER E3867
 TEST PER E3856-D

| | | | |
|---|---|----------------------------|--|
| PROPRIETARY & CONFIDENTIAL. THIS DOCUMENT CONTAINS PROPRIETARY INFORMATION OWNED BY LINCOLN GLOBAL, INC. AND MAY NOT BE DUPLICATED, COMMUNICATED TO OTHER PARTIES OR USED FOR ANY PURPOSE WITHOUT THE EXPRESS WRITTEN PERMISSION OF LINCOLN GLOBAL, INC. | | | |
| MANUFACTURING TOLERANCE PER E2059 UNLESS OTHERWISE SPECIFIED TOLERANCE: ON 2 PLACE DECIMALS IS ± .02 ON 3 PLACE DECIMALS IS ± .002 ON ALL ANGLES IS ± .5 OF A DEGREE MATERIAL TOLERANCE ("I") TO AGREE WITH PUBLISHED STANDARDS. DO NOT SCALE THIS DRAWING | DESIGN INFORMATION DRAWN BY: <i>gmaddie</i> ENGINEER: APPROVED: <i>DLS</i> | REFERENCE: - SCALE: 1:1 | EQUIPMENT TYPE: MISCELLANEOUS SUBJECT: SPI DISPLAY P.C. BOARD ASSEMBLY MATERIAL DISPOSITION: UF APPROVAL DATE: 11/05/2004 PROJECT NUMBER: CRM36635 |
| PAGE 1 OF 1 | | | DOCUMENT NUMBER: L11757-1 DOCUMENT REVISION: A |

NOTE: Lincoln Electric assumes no responsibility for liabilities resulting from board level troubleshooting. PC Board repairs will invalidate your factory warranty. **Individual Printed Circuit Board Components are not available from Lincoln Electric.** This information is provided for reference only. Lincoln Electric discourages board level troubleshooting and repair since it may compromise the quality of the design and may result in danger to the Machine Operator or Technician. Improper PC board repairs could result in damage to the machine.



SCHEMATIC - VOLTAGE SENSE SELECT PC BOARD - (S24779)

Return to Section TOC
Return to Master TOC

Return to Section TOC
Return to Master TOC

Return to Section TOC
Return to Master TOC

Return to Section TOC
Return to Master TOC

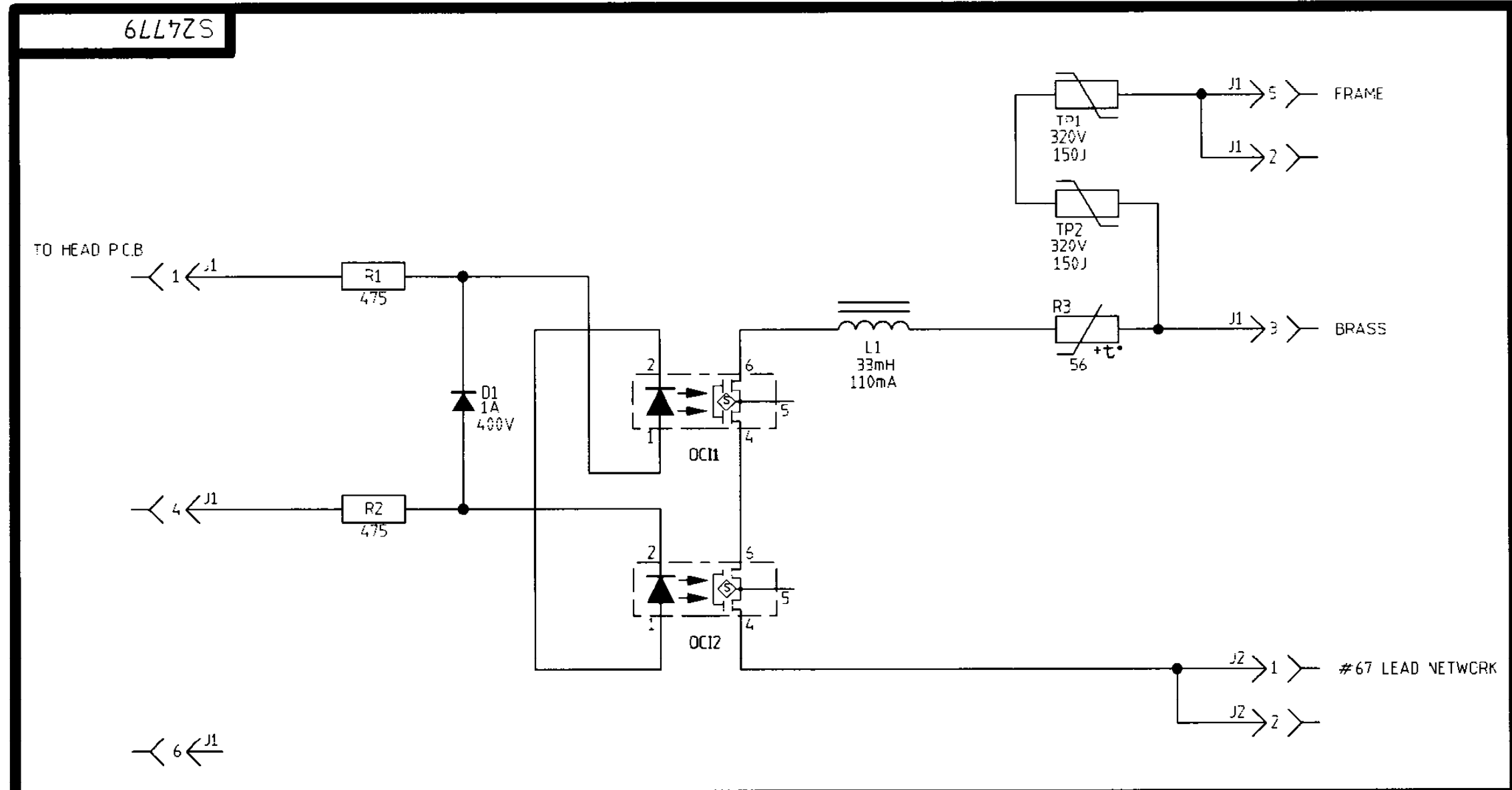

THIS SHEET CONTAINS PROPRIETARY INFORMATION OWNED BY THE LINCOLN ELECTRIC CO. AND IS NOT TO BE REPRODUCED, DISCLOSED OR USED WITHOUT THE EXPRESS PERMISSION OF THE LINCOLN ELECTRIC CO. CLEVELAND, OHIO U.S.A.

NOTES :
 N.A. SINCE COMPONENTS OR CIRCUITRY ON A PRINTED CIRCUIT BOARD MAY CHANGE WITHOUT AFFECTING THE INTERCHANGEABILITY OF A COMPLETE BOARD, THIS DIAGRAM MAY NOT SHOW THE EXACT COMPONENTS OR CIRCUITRY OF CONTROLS HAVING A COMMON CODE NUMBER.

GENERAL INFORMATION
 ELECTRICAL SYMBOLS PER E1537
 CAPACITORS = MFD (----- UNLESS OTHERWISE SPECIFIED)
 RESISTORS = Ohms (----- UNLESS OTHERWISE SPECIFIED)
 DIODES = ----- UNLESS OTHERWISE SPECIFIED)

LABELS
 ▲ SUPPLY VOLTAGE NET
 ○ POWER SUPPLY SOURCE POINT
 ▽ COMMON CONNECTION

FRAME CONNECTION
 EARTH GROUND CONNECTION

| LAST NO. USED | |
|---------------|-------|
| R- 3 | L- 1 |
| C- - | OC- 2 |
| D- 1 | TP- 2 |

FILENAME: S24779_1AA

| | | | | |
|--|---------------------------|----------|------------------------|---|
| UNLESS OTHERWISE SPECIFIED TOLERANCE ON HOLES SIZES PER E2056 ON 2 PLACE DECIMALS IS ± .02 ON 3 PLACE DECIMALS IS ± .002 ON ALL ANGLES IS ± .5 OF A DEGREE MATERIAL TOLERANCE (±t) TO AGREE WITH PUBLISHED STANDARDS | Chg. Sheet No. | *X* INFO | DESIGN INFORMATION | EQUIPMENT TYPE: SWG |
| | XA | | DRAWN BY: FM <i>LM</i> | SUBJECT: VOLTAGE SENSE SELECT PCB SCHEM. |
| | 11-3-2000A | | ENGINEER: KC <i>MS</i> | DATE: 10/23/00 SCALE: NONE REF.: ----- DRWG. NO. S24779 |
| | DO NOT SCALE THIS DRAWING | | REVISED BY: --- | |

NOTE: This diagram is for reference only. It may not be accurate for all machines covered by this manual.

PC BOARD ASSEMBLY - VOLTAGE SENSE SELECT (M19540)

Return to Section TOC
Return to Master TOC

Return to Section TOC
Return to Master TOC

Return to Section TOC
Return to Master TOC

Return to Section TOC
Return to Master TOC

M19540-3

ENGINEERING CONTROLLED CHANGE DETAIL: REVISED MAKE SPECIFICATION
MANUFACTURER: No

P.C. BOARD BLANK INFORMATION
BUY COMPLETE AS M19540-C
(2 LAYER BOARD PER E3281)
(MAKES 54 BOARDS PER PANEL, SEE ELECTRONIC FILE
FOR ADDITIONAL INFORMATION)

| ITEM | REQD | PART NO. | IDENTIFICATION |
|-----------|------|-------------|----------------|
| C1 | 1 | S20500-4 | .0047 1000V |
| D1 | 1 | T12199-1 | 1N4004 |
| N.A. J1 | 1 | S24020-6 | HEADER |
| N.A. J2 | 1 | S24020-2G | HEADER |
| L1 | 1 | T12218-7 | 330uH |
| OCI1,OCI2 | 2 | S15000-20 | PHOTO FET |
| R1,R2 | 2 | S19400-4750 | 475 1/4W |
| R3 | 1 | S18380-1 | THERMISTOR,PTC |
| TP1,TP2 | 2 | T13640-18 | 160J |

CAPACITORS = MFD/VOLTS
RESISTORS = OHMS
INDUCTANCE = HENRYS

| ITEM | REQD | PART NO. | DESCRIPTION |
|------|------|----------------|------------------|
| 1 | 1 | SEE BLANK INFO | P.C. BOARD BLANK |

SCHEMATIC REFERENCE: S24779-3CO

N.A. DO NOT COAT WITH ENCAPSULATION MATERIAL.
N.B. DO NOT COAT WITH ENCAPSULATION MATERIAL
.23 MIN. DIA. (3 PLACES) ON NON COMPONENT SIDE.

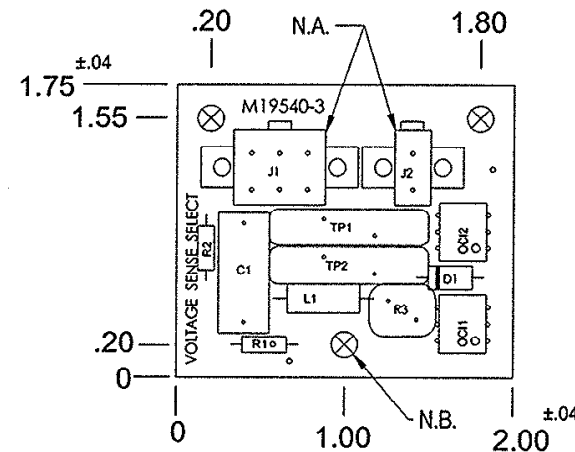

MANUFACTURED AS

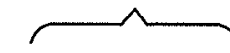

M19540-3CO

IDENTIFICATION CODE

MAKE PER E1911-ROHS
ENCAPSULATE WITH E1844 (2 DIPS)
TEST PER E3689-VS

ALL COMPONENTS AND MATERIALS USED IN THIS
ASSEMBLY ARE TO BE RoHS COMPLIANT PER E4253.

| | | | |
|--|--------------------|--------------------------|---|
| PROPRIETARY & CONFIDENTIAL THIS DOCUMENT CONTAINS PROPRIETARY INFORMATION OWNED BY LINCOLN GLOBAL, INC. AND MAY NOT BE DUPLICATED, COMMUNICATED TO OTHER PARTIES OR USED FOR ANY PURPOSE WITHOUT THE EXPRESS WRITTEN PERMISSION OF LINCOLN GLOBAL, INC. | | | |
| UNLESS OTHERWISE SPECIFIED TOLERANCE MANUFACTURING TOLERANCE PER E2056 ON 2 PLACE DECIMALS IS ±.02 ON 3 PLACE DECIMALS IS ±.002 ON ALL ANGLES IS ±.5 OF A DEGREE MATERIAL TOLERANCE ("L") TO AGREE WITH PUBLISHED STANDARDS. DO NOT SCALE THIS DRAWING | DESIGN INFORMATION | REFERENCE: | EQUIPMENT TYPE: COMMON DIGITAL CONTROLS |
| | DRAWN BY: FEI | M19540-2 | SUBJECT: VOLTAGE SENSE PC BRD AS'BLY |
| ENGINEER: | SCALE: | MATERIAL DISPOSITION: UF | APPROVAL DATE: 3/16/2007 |
| APPROVED: <i>DW</i> | 1:1 | PROJECT NUMBER: CRM34409 | PAGE 1 OF 1 |
| | | | DOCUMENT NUMBER: M19540-3 |
| | | | DOCUMENT REVISION: C |

NOTE: Lincoln Electric assumes no responsibility for liabilities resulting from board level troubleshooting. PC Board repairs will invalidate your factory warranty. **Individual Printed Circuit Board Components are not available from Lincoln Electric.** This information is provided for reference only. Lincoln Electric discourages board level troubleshooting and repair since it may compromise the quality of the design and may result in danger to the Machine Operator or Technician. Improper PC board repairs could result in damage to the machine.



SOLID EDGE

STRP

SCHEMATIC - SPOOL GUN PC BOARD (L12008)

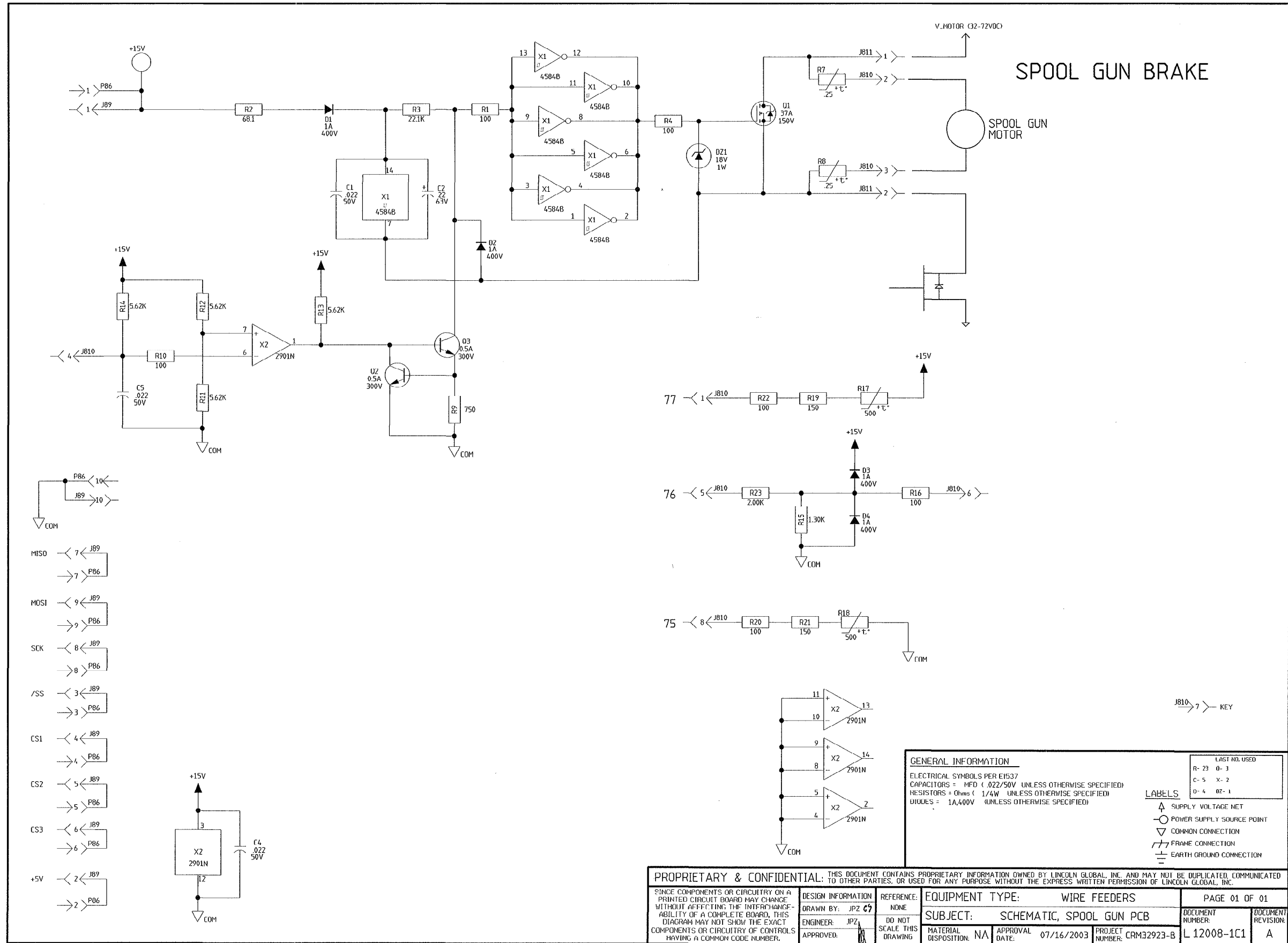

Return to Section TOC
 Return to Master TOC
 Return to Section TOC
 Return to Master TOC
 Return to Section TOC
 Return to Master TOC
 Return to Section TOC
 Return to Master TOC

NOTE: This diagram is for reference only. It may not be accurate for all machines covered by this manual.



| | | | | |
|--|---|---|--|--|
| PROPRIETARY & CONFIDENTIAL: THIS DOCUMENT CONTAINS PROPRIETARY INFORMATION OWNED BY LINCOLN GLOBAL, INC. AND MAY NOT BE DUPLICATED, COMMUNICATED TO OTHER PARTIES, OR USED FOR ANY PURPOSE WITHOUT THE EXPRESS WRITTEN PERMISSION OF LINCOLN GLOBAL, INC. | | GENERAL INFORMATION ELECTRICAL SYMBOLS PER E1537 CAPACITORS = MFD (.022/50V UNLESS OTHERWISE SPECIFIED) RESISTORS = Ohms (1/4W UNLESS OTHERWISE SPECIFIED) DIODES = 1A,400V (UNLESS OTHERWISE SPECIFIED) | | LAST NO. USED R- 23 0- 3 C- 5 X- 2 D- 4 02- 1 |
| DESIGN INFORMATION DRAWN BY: JPZ 67 ENGINEER: JPZ APPROVED: | REFERENCE: NONE DO NOT SCALE THIS DRAWING | EQUIPMENT TYPE: WIRE FEEDERS SUBJECT: SCHEMATIC, SPOOL GUN PCB MATERIAL DISPOSITION: NA APPROVAL DATE: 07/16/2003 PROJECT NUMBER: CRM32923-B | PAGE 01 OF 01 DOCUMENT NUMBER: L 12008-1C1 DOCUMENT REVISION: A | |

PC BOARD ASSEMBLY - SPOOL GUN (M20159)

Return to Section TOC
Return to Master TOC

Return to Section TOC
Return to Master TOC

Return to Section TOC
Return to Master TOC

Return to Section TOC
Return to Master TOC

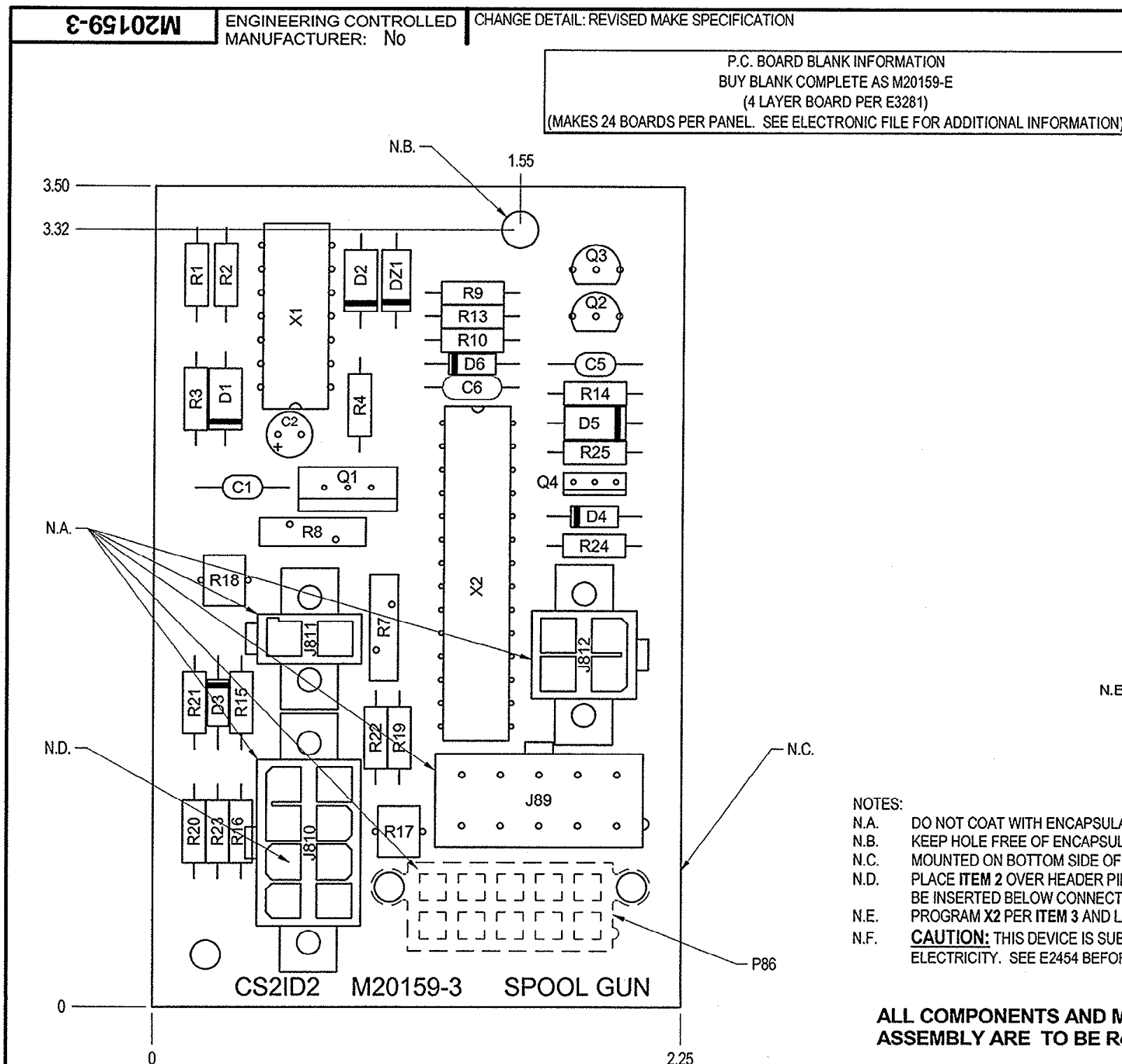

| ITEM (USED WITH)* | QTY | PART NUMBER | DESCRIPTION |
|-------------------|-----|----------------|----------------|
| 1 | 1 | SEE BLANK INFO | PC BOARD BLANK |
| 2 (J810-7)* | 1 | S24671 | KEYING PAD |
| 3 (X2)* | 1 | Y00725-1 | SOFTWARE |

REFER TO ELECTRONIC COMPONENT DATABASE FOR SPECIFICATIONS ON ITEMS LISTED BELOW

| REFERENCES | QTY | PART NUMBER | DESCRIPTION |
|--------------------------------------|-----|-------------|---|
| C1, C5 | 2 | S16668-5 | CAPACITOR,CEMO.,022,50V,20% |
| C2 | 1 | S13490-181 | CAPACITOR,ALEL,22,63V,20% |
| C6 | 1 | S16668-11 | CAPACITOR,CEMO,0.1, 50V, 10% |
| D1, D2, D5 | 3 | T12199-1 | DIODE,AXLDS,1A,400V |
| D3, D4, D6 | 3 | T12705-64 | DIODE,SCHOTTKY,AXLDS,0.2A,30V,BAT42 |
| DZ1 | 1 | T12702-45 | ZENER DIODE,1W,18V,5%,1N4746A |
| J89 | 1 | S18248-10 | CONNECTOR,MOLEX,MINI,PCB,10-PIN |
| J810 | 1 | S24020-8 | CONNECTOR,MOLEX,MINI,PCB,8-PIN,TIN |
| J811 | 1 | S24020-2G | CONNECTOR,MOLEX,MINI,PCB,2-PIN,GOLD |
| J812 | 1 | S24020-4 | CONNECTOR,MOLEX,MINI,PCB,4-PIN,TIN |
| P86 | 1 | S21135-10 | CONNECTOR,MOLEX,MINI,BLIND,F,10-PIN |
| N.F. Q1 | 1 | T12704-98 | TRANSISTOR,NMF,TO220,37A,150V,FDP2552(SS) |
| Q2, Q3 | 2 | T12704-35 | TRANSISTOR,NPN,TO226,0.5A, 300V,MPS-A42 |
| N.F. Q4 | 1 | T12704-109 | TRANSISTOR,NMF,IPAK,TO-251,10A,100V(SS) |
| R1, R4, R10, R13, R16, R20, R22, R24 | 8 | S19400-1000 | RESISTOR,MF,1/4W,100,1% |
| R2 | 1 | S19400-68R1 | RESISTOR,MF,1/4W,68.1,1% |
| R3 | 1 | S19400-2212 | RESISTOR,MF,1/4W,22.1K,1% |
| R7, R8 | 2 | S18380-4 | THERMISTOR,.02-.47 OHMS, 0.9AMP |
| R9 | 1 | S19400-7500 | RESISTOR,MF,1/4W,750,1% |
| R14 | 1 | S19400-1502 | RESISTOR,MF,1/4W,15.0K,1% |
| R15 | 1 | S19400-1301 | RESISTOR,MF,1/4W,1.30K,1% |
| R17, R18 | 2 | S18380-14 | THERMISTOR,PTC,500OHMS,28mA |
| R19, R21 | 2 | S19400-1500 | RESISTOR,MF,1/4W,150,1% |
| R23 | 1 | S19400-2001 | RESISTOR,MF,1/4W,2.00K,1% |
| R25 | 1 | S19400-1002 | RESISTOR,MF,1/4W,10.0K,1% |
| N.F. X1 | 1 | S15018-4 | IC,CMOS,INVERTER,SCHMITT, HEX,4584(SS) |
| N.E.,N.F. X2 | 1 | S25073-9 | IC,CMOS,PSOC,8-BIT,CY8C27443,DIP-28(SS) |

UNLESS OTHERWISE SPECIFIED:
 CAPACITANCE = MFD/VOLTS
 INDUCTANCE = HENRIES
 RESISTANCE = OHMS

- NOTES:
 N.A. DO NOT COAT WITH ENCAPSULATION MATERIAL.
 N.B. KEEP HOLE FREE OF ENCAPSULATION MATERIAL.
 N.C. MOUNTED ON BOTTOM SIDE OF P.C. BOARD.
 N.D. PLACE ITEM 2 OVER HEADER PIN AS SHOWN. ITEM 2 SHOULD BE INSERTED BELOW CONNECTOR TOP SURFACE.
 N.E. PROGRAM X2 PER ITEM 3 AND LABEL X2 WITH PART OF ITEM 3.
 N.F. **CAUTION:** THIS DEVICE IS SUBJECT TO DAMAGE BY STATIC ELECTRICITY. SEE E2454 BEFORE HANDLING.

MAKE PER E1911-ROHS
 ENCAPSULATE WITH E1844 (2 DIPS)
 TEST PER E4190-SP

SCHEMATIC REFERENCE: L12008-3E0

MANUFACTURE AS:

M 2 0 1 5 9 - 3 E 0

PART NUMBER IDENTIFICATION CODE

ALL COMPONENTS AND MATERIALS USED IN THIS ASSEMBLY ARE TO BE RoHS COMPLIANT PER E4253.

| | | | |
|--|---|---|---|
| PROPRIETARY & CONFIDENTIAL - THIS DOCUMENT CONTAINS PROPRIETARY INFORMATION OWNED BY LINCOLN GLOBAL, INC. AND MAY NOT BE DUPLICATED, COMMUNICATED TO OTHER PARTIES OR USED FOR ANY PURPOSE WITHOUT THE EXPRESS WRITTEN PERMISSION OF LINCOLN GLOBAL, INC. | | | |
| MANUFACTURING TOLERANCE PER E2059 UNLESS OTHERWISE SPECIFIED TOLERANCE ON 2 PLACE DECIMALS IS ± .02 ON 3 PLACE DECIMALS IS ± .002 ON ALL ANGLES IS ± .5 OF A DEGREE MATERIAL TOLERANCE ("I") TO AGREE WITH PUBLISHED STANDARDS. DO NOT SCALE THIS DRAWING | DESIGN INFORMATION DRAWN BY: FEI ENGINEER: APPROVED: [Signature] | REFERENCE: M20159-2 SCALE: 2:1 | EQUIPMENT TYPE: POWER MIG 350MP SUBJECT: SPOOL GUN P. C. BOARD ASSEMBLY MATERIAL DISPOSITION: UF APPROVAL DATE: 03/16/2007 PROJECT NUMBER: CRM34409 |
| | | PAGE 1 OF 1 | DOCUMENT NUMBER: M20159-3 DOCUMENT REVISION: B |

EN-166

SOLID EDGE

NOTE: Lincoln Electric assumes no responsibility for liabilities resulting from board level troubleshooting. PC Board repairs will invalidate your factory warranty. **Individual Printed Circuit Board Components are not available from Lincoln Electric.** This information is provided for reference only. Lincoln Electric discourages board level troubleshooting and repair since it may compromise the quality of the design and may result in danger to the Machine Operator or Technician. Improper PC board repairs could result in damage to the machine.